



# A review of solar photovoltaic technologies: developments, challenges, and future perspectives

Saeed Al-Ali <sup>a,b,\*</sup>, Abdul Ghani Olabi <sup>a,c</sup>, Montaser Mahmoud <sup>a</sup>

<sup>a</sup> Sustainable Energy & Power Systems Research Centre, RISE, University of Sharjah, P.O. Box 27272, Sharjah, United Arab Emirates

<sup>b</sup> Department of Industrial and Management Engineering, University of Sharjah, P.O. Box 27272, Sharjah, United Arab Emirates

<sup>c</sup> Mechanical Engineering and Design, Aston University, School of Engineering and Applied Science, Aston Triangle, Birmingham B4 7ET, UK

## ARTICLE INFO

### Keywords:

Photovoltaic  
Solar energy  
Renewable energy  
Technological advancements  
Market dynamics

## ABSTRACT

Solar photovoltaic (PV) technology has emerged as a key renewable energy solution, yet its widespread adoption faces several technical and economic challenges. This review examines the evolution, current advancements, and future prospects of PV systems, highlighting the development of various photovoltaic cell technologies, including crystalline silicon, amorphous silicon, cadmium telluride, perovskite, and organic solar cells. The study explores the operational principles of stand-alone and grid-tied PV systems and their economic significance. A historical perspective is provided, tracing PV technology from the discovery of the photovoltaic effect in 1839 to its latest innovations, such as high-efficiency cells, bifacial panels, solar shingles, transparent solar cells, and PV-driven hydrogen production. The methodology involves an extensive review of recent advancements, industry trends, and existing literature to identify key challenges in PV deployment, including efficiency losses, high initial costs, and market integration barriers. Findings indicate that while significant progress has been made, further research and policy support are needed to enhance technology efficiency, reduce costs, and ensure seamless integration into energy markets.

## 1. Introduction

Solar PV is considered one of the most decarbonized electricity generation systems, offering a promising solution to mitigate climate change and enhance energy security. By reducing greenhouse gas (GHG) emissions and providing a scalable and reliable energy source, solar PV plays a key role in addressing global sustainability challenges [1]. Beyond its environmental benefits, solar PV aligns with the United Nations' SDGs "Sustainable Development Goals", particularly SDG 7, by enhancing access to affordable, reliable, and sustainable energy [2].

In recent years, massive research and development (R&D) efforts have been directed towards advancing solar PV technologies. These efforts have led to significant advancements in solar cell technologies, focusing on improving efficiency and reducing costs. Other key advancements include bi-facial photovoltaic panels that absorb sunlight on both sides [3], solar trackers that enhance energy capture by adjusting panel orientation [4], solar shingles or building integrated PV that integrate seamlessly into building architecture [5], and transparent solar cells that can be incorporated into windows and other surfaces for energy generation [6]. These breakthroughs highlight the rapid progress

in solar PV technology, underscoring ongoing efforts to optimize performance and facilitate widespread adoption.

The global solar PV industry has experienced remarkable growth in recent years, with cumulative installed capacity reaching 1.6 TW in 2023, up from 1.2 TW in 2022 [7]. According to the Global Solar Council, global PV capacity has now surpassed 2 TW, marking a rapid acceleration in deployment. While it took nearly seven decades (1954–2022) to install the first terawatt of solar power, the second terawatt was achieved in just two years (2022–2024). Estimates from the council and SolarPower Europe indicate that around 7 billion solar panels and 25 million solar-powered homes are now in operation worldwide. With annual installations reaching approximately 500 GW and global manufacturing capacity at 1.1 TW, the PV industry is well-positioned to support the goal of tripling global renewable energy capacity by 2030. However, according to the International Renewable Energy Agency (IRENA), meeting the 1.5 °C climate target by 2050 will require substantial financial investment, around \$150 trillion in total [8].

However, despite these advancements, significant challenges remain [9–11]. High initial investment costs [12], efficiency losses due to

\* Corresponding author.

E-mail address: [u19102773@sharjah.ac.ae](mailto:u19102773@sharjah.ac.ae) (S. Al-Ali).

<https://doi.org/10.1016/j.ecmx.2025.101057>

Received 11 February 2025; Received in revised form 6 April 2025; Accepted 7 May 2025

Available online 10 May 2025

2590-1745/© 2025 The Author(s). Published by Elsevier Ltd. This is an open access article under the CC BY license (<http://creativecommons.org/licenses/by/4.0/>).

environmental factors like dust and heat [13–15], and the need for effective recycling and disposal solutions for PV materials [16] are some of the obstacles impeding the full potential of solar PV technologies. Additionally, integrating solar PV into existing grid infrastructures and achieving cost parity with conventional energy sources continue to be pressing concerns. Moreover, extreme weather conditions, such as wildfires, hurricanes, and severe heatwaves, pose additional threats to the resilience of PV systems by affecting power grid stability and reducing solar generation efficiency [17–19]. For example, wildfire byproducts, including heat, smoke, and ash, can degrade panel performance, while excessive heat can alter powerline capacity and overall grid reliability [20]. Another example is hurricanes, which can cause physical damage to PV installations, disrupt grid connectivity, and lead to prolonged power outages, further challenging the reliability and resilience of solar energy systems [21]. Addressing these challenges requires sustained innovation, supportive policies, and collaborative efforts across governments, industries, and academia to ensure solar PV reaches its full potential as a cornerstone of a sustainable energy future.

This review paper provides a comprehensive analysis of solar photovoltaics, covering key aspects such as the historical development of PV technology, different photovoltaic cell types, current trends, challenges, and future prospects. It explores various PV technologies, including crystalline silicon, amorphous silicon, cadmium telluride, and emerging options like perovskite and organic solar cells. The paper also examines recent innovations aimed at improving efficiency and expanding applications. Additionally, it discusses economic and technical barriers to widespread adoption, such as high initial costs, efficiency losses, and market integration issues. Unlike existing reviews that focus on specific technologies or aspects, this study offers a holistic perspective on the evolution of the PV sector and its challenges. By synthesizing these insights, it highlights the current state of solar PV and outline strategic directions for its future growth and integration into global energy systems. To guide this analysis, the review considers the following research hypotheses:

- The expansion of the PV sector is dependent on overcoming the technology transfer and market transfer gaps, which have historically hindered scalability and competitiveness against conventional energy sources.
- The large-scale deployment of PV systems remains limited due to the high cost of energy storage solutions.

- Supportive policies, including government incentives, tax credits, and investment in grid modernization, are essential for accelerating PV adoption, closing diffusion gaps, and ensuring long-term market sustainability.

## 2. Solar photovoltaic systems: overview

The fundamental physical mechanism by which a PV cell turns solar energy into electrical energy is known as the photovoltaic effect [22,23]. Sunlight is formed from solar energy particles named photons, which resemble energy accumulations. The energy of these photons varies with their wavelengths in the solar spectrum. When photons encounter a photovoltaic cell, they can be either absorbed or reflected. Electricity is only produced by photons that are absorbed. When this occurs, the photon's energy is converted to an electron in a cell atom (often an atom of silicon). In an electrical circuit, the electron can break free from its usual location inside the atom and join the current.

In order to produce a PV cell's electric field, manufacturers create a junction by joining two distinct types of semiconductors (P and N), which generates the electric field within the photovoltaic cell, as shown in Fig. 1. Adding an element with an extra electron or an electron shortage is the most common technique for producing P-type or N-type silicon material. The ability of a photon to excite an electron depends on the bandgap energy of the semiconductor material. When a photon transfers enough energy, an electron is excited from the valence band to the conduction band, creating an electron-hole pair. The built-in electric field at the p-n junction then plays a crucial role in separating these charge carriers. It directs the free electrons toward the n-type region and holes toward the p-type region, generating an electric potential difference. This movement of electrons results in the formation of an electrical current when the circuit is closed. However, some charge carriers may recombine before contributing to electricity generation, reducing efficiency [24,25].

Silicon is the most frequent material utilized in the manufacturing of solar cells. It has a bandgap of approximately 1.1 eV, meaning it can absorb photons with energy equal to or greater than this threshold. There are 14 electrons in an atom of silicon; the four electrons in the final layer are referred to as valence electrons. Each silicon atom in a crystal solid typically forms a covalent connection with another silicon atom to share one of its four valence electrons. Five silicon atoms arranged in a covalent connection make up the silicon crystal molecule. Silicon-based PV cells are typically manufactured through a series of

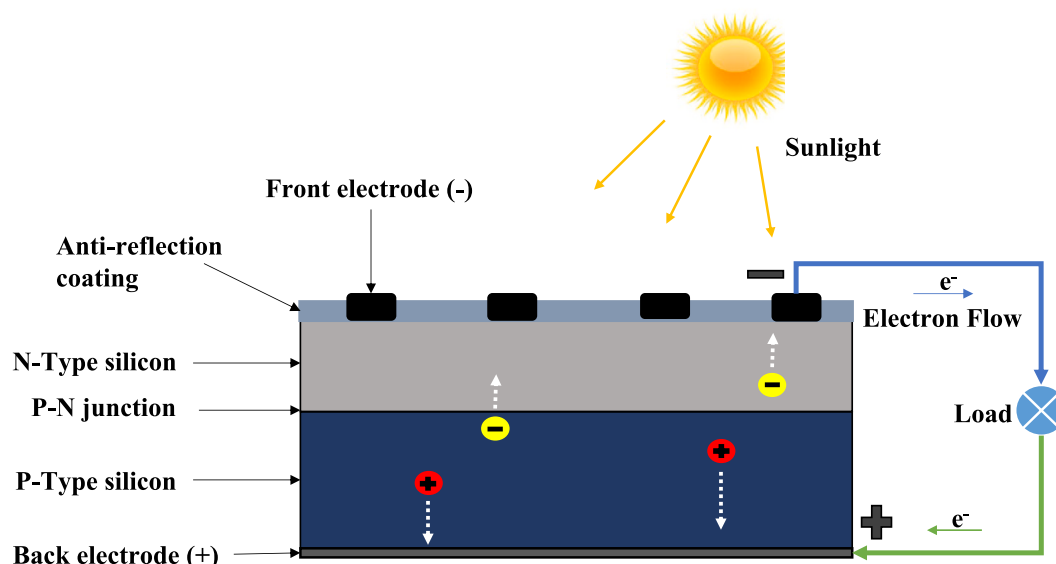

Fig. 1. Schematic diagram of a photovoltaic cell.

processes, including purification, crystallization, wafer production, doping, and cell assembly. High-purity silicon is obtained through the Siemens process, where metallurgical-grade silicon is refined into polysilicon. This is then formed into either monocrystalline or polycrystalline ingots through the Czochralski or casting methods, respectively. The ingots are sliced into thin wafers, which are treated through doping to create p-type and n-type layers. Additional steps such as surface texturing, anti-reflective coating application, and metallization enhance efficiency by reducing energy losses and improving charge collection. Emerging materials, such as perovskite and organic solar cells, offer alternative manufacturing techniques, often involving solution-based processing or thin-film deposition, which can reduce costs and improve flexibility [26,27].

Pragmatically, the structure of the PV system is considered to be profoundly flexible by all means. PV modules in other words constitute to be the primary building blocks of the system which can be organized into a method to produce as much electricity surplus as possible. On a normative situation, a wide range of supporting equipment is deemed to be crucial to transform energy into any meaningful form of electricity storage. Hence the resulting system shall be determined purely considering the need of energy or loads in a specific application. PV systems are categorized into two vital groups, stand-alone and grid-tied systems [28,29], which will be discussed in detail in the following subsections. Table 1 shows a comparison of these two systems in terms of key features, advantages, and limitations.

### 2.1. Stand-alone systems

When a system is described as stand-alone system or in other word called off-grid system, it means that it is the only source of electricity for houses and any additional uses it may have, including emergency call boxes on roads, distant cottages, telecom sites, water pumps, and street lighting. Systems that are meant to function independently usually have batteries for energy storage (see Fig. 2). Energy produced during the day is stored in a battery bank by battery backup systems for usage during nighttime. Compared to other standalone systems or alternatives like utility line extensions, they are consistently more affordable. On the other hand, if the usage of PV cannot cover the power demand from

**Table 1**  
Comparison of stand-alone and grid-tied solar PV systems.

System	Stand-alone	Grid-tied
Features	<ul style="list-style-type: none"> <li>- Operates independently without grid connection.</li> <li>- Requires battery storage for energy use during nighttime or low sunlight.</li> <li>- Suitable for remote locations, emergency power, telecom sites, water pumps, and street lighting.</li> </ul>	<ul style="list-style-type: none"> <li>- Connected to the utility grid for energy exchange.</li> <li>- No need for battery storage as excess energy is fed into the grid.</li> <li>- Common in residential, commercial, and industrial settings with grid access.</li> </ul>
Advantages	<ul style="list-style-type: none"> <li>- Provides electricity in areas without grid access.</li> <li>- Ensures power availability during grid outages.</li> <li>- Can integrate with other renewable sources like wind or biodiesel generators for reliability.</li> </ul>	<ul style="list-style-type: none"> <li>- Reduces electricity bills through net metering (selling excess energy to the grid).</li> <li>- No battery costs, reducing installation and maintenance expenses.</li> <li>- Higher efficiency as power is used immediately or credited to the grid.</li> </ul>
Limitations	<ul style="list-style-type: none"> <li>- High initial cost due to battery storage.</li> <li>- Battery maintenance and replacement costs.</li> <li>- Limited power supply when solar generation is low and batteries are depleted.</li> </ul>	<ul style="list-style-type: none"> <li>- No power supply during grid outages unless a backup battery or generator is installed.</li> <li>- Requires utility approvals and compliance with grid regulations.</li> <li>- Potential interconnection fees and dependency on grid stability.</li> </ul>

consumer, this will result in using the power from the utilities. The monthly electric utility statement for the consumer in these circumstances will simply show the consumed energy received from the utility company [30].

Stand-alone systems are not connected to the grid for electricity distribution, and they include every component required to supply AC appliances in a typical home or business setting. The reliability could be increased by adding another generator (such as a wind or biodiesel generator), but it is not always required. The type of load being supplied will determine how many components the system should have. If the PV modules are solely going to feed DC loads, then the inverter could be removed or switched out for a DC-to-DC converter. Another approach involves directly connecting a PV array to a DC load.

Living in a house or cabin off the grid means that you are not linked to any utilities. The expense of bringing in electricity from the utility is one drawback of living in a distant location. A homeowner would have to rely on propane gas, a generator powered by fossil fuels, or both. These days, a house or lodge unconnected to the local utility can be powered by a battery-powered solar photovoltaic system, which is off the grid. While solar PV modules and batteries provide DC electricity, most electrical loads found in homes run on AC. To transform DC electrical current to AC electrical current, an inverter is utilized. Similar to controllers, inverters have a selection of sizes and capacities to meet the needs of the customer. It is crucial to account for all of the electrical loads that the solar PV is able to power when building a battery-based system. The calculation will take into account the number of hours/day and the number of days/month that the loads will be in use. When a system's capacity is exceeded by additional loads, it becomes inefficient and must wait for the PV array to replenish the battery bank [31].

### 2.2. Grid tied systems

An additional source of electricity to the current utility company supply is provided via a "grid-connected" system [32,33]. Excess energy from a grid-connected photovoltaic system is exported to the utility when it surpasses the customer's loads, turning the electric meter of the consumer backward. These systems don't need battery storage because they are directly connected to the electric distribution network, as presented in Fig. 3. Depending on local energy usage patterns and day-to-day variations in solar resources, electricity is either purchased or sold from the local electric utility. Compared to conventional stand-alone schemes, grid-tied photovoltaic systems have numerous advantages.

- Smaller PV arrays can supply the same load.
- Removes the requirement for energy storage and related expenses.
- Benefits from the current electricity infrastructure.
- Effective utilization of energy resources, as it helps generate the necessary electrical grid supply when customer demand is lower than PV output.

For added scheduling flexibility and reliability, hybrid systems that include grid connection and battery storage or a generator or together are feasible (at additional expense). Grid-connected systems are among the PV system types with the quickest rate of growth. Grid-connected systems, both residential and commercial, are popular ways to cut back on the amount of electricity provided by the local utility. Similar to the stand-alone PV, an inverter is utilized in the grid-connected system to transform DC electricity into AC electricity, and a solar array is composed of connected photovoltaic modules [34].

By producing and transferring more electricity to the utility than the owner consumes when the PV system is operating, the owner can save money. The technique of figuring out how much electricity a property owner uses from the utility and how much power they provide to them is known as net-metering. The inverter is made to shut down and not deliver any power from the system to the utility in the occurrence of a

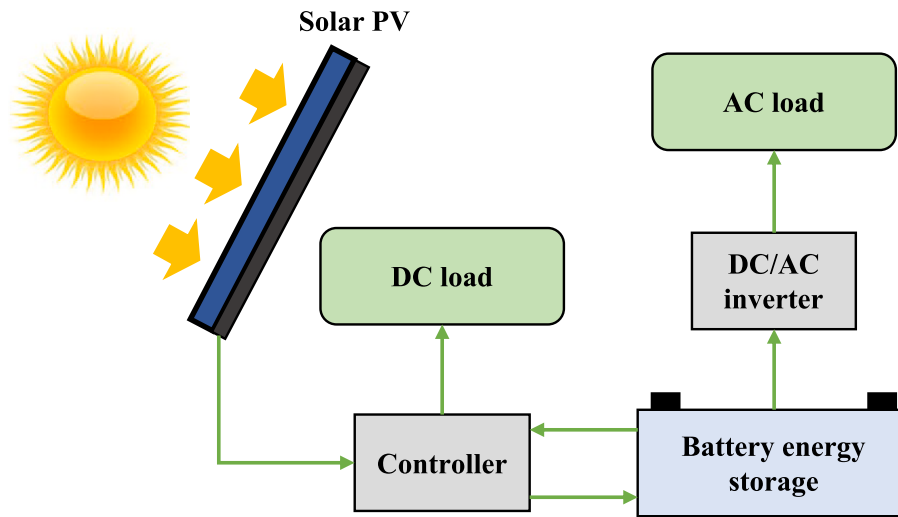

Fig. 2. Stand-alone solar PV system layout.

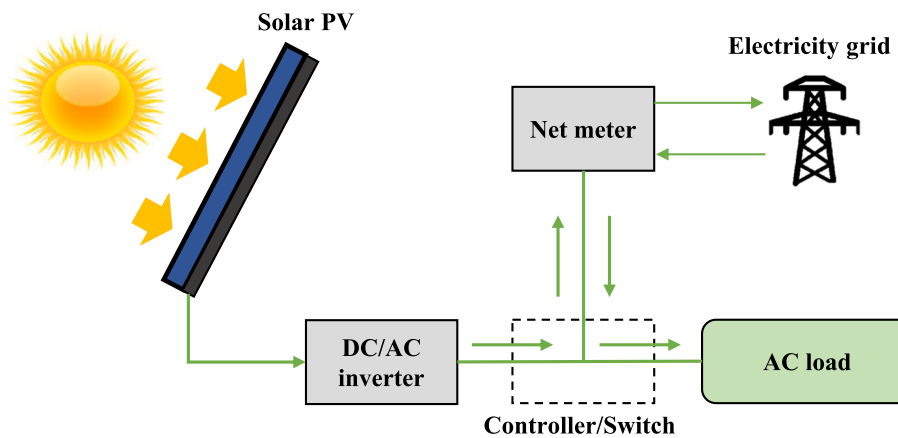

Fig. 3. Grid-tied solar PV system layout.

utility-side power outage for safety reasons. This is intended to safeguard utility employees who could be repairing power wires. Grid-connect systems function well in homes when the occupants are away at work or school during the day and the electrical loads are low. The PV system generates credit for the owner with the local utility during the day when it produces more electricity than the residence's load demand. The utility will supply electricity for the electrical demands when the inhabitants return at the end of the day. The initial costs of establishing a system are partially mitigated by state and federal incentives and rebates. In order to supply backup electricity in the event of a utility outage, a grid-connected system may be supported by a battery bank or a generator. During the day, the solar array powers the system and charges the battery bank. The battery bank or the electrical generator can provide electricity during a cloudy condition or at night.

### 2.3. The economic value of solar PV systems

There are several economic benefits associated with the use of PV, including a reduction in utility bills, job creation, improved ability to cope with emergency situations, and access to installation incentives. Consumers can lower their monthly power expenditure by investing in and installing solar energy systems. In addition to the clean energy produced, this can help balance the expense of the household's power use. As a result, consumers will make fewer payments in the long run, which will allow investors to recover their investment costs. Unlike

conventional electricity sources that are subject to fuel price volatility, solar PV systems provide a predictable and stable energy cost, protecting consumers from rising electricity prices and market fluctuations [35–37].

Through net metering, certain utility providers let consumers sell any extra energy that is produced by PV. Users will save money on their monthly electricity bills and the clean energy that is produced will benefit others in the community. This financial benefit not only incentivizes residential adoption but also encourages businesses to invest in larger-scale PV installations, leading to increased energy independence and reduced strain on national power grids [38,39].

More energy workers are required to meet the growing demand as more consumers show interest in installing solar panels to fulfill the need. This sector demands workforce participation in production, installation, and upkeep. Investing in solar energy not only boosts the local economy but also generates new employment opportunities. According to industry reports, the solar sector has experienced significant growth in employment compared to fossil fuel industries, creating jobs in research, engineering, sales, and maintenance. Moreover, expanding the PV market promotes technological innovation, leading to advancements in efficiency and cost reduction, further enhancing its economic viability.

Natural disasters such as hurricanes, floods, and earthquakes can interfere with the grid's power supply. Thankfully, in times of emergency, solar panels offer a strong substitute for conventional electricity.

When other energy sources, like fossil fuels, are unavailable, solar panels will still receive the required sunlight to generate energy. This energy resilience is particularly beneficial in rural and off-grid areas, where PV systems provide a decentralized solution, reducing dependence on expensive and vulnerable transmission infrastructure. Additionally, integrating solar PV with battery storage enhances reliability, ensuring power availability even during nighttime or extreme weather conditions.

Furthermore, switching to solar energy systems can reduce carbon emissions, which contribute to climate change and intensify natural disasters. Lowering dependence on fossil fuels not only mitigates environmental impacts but also reduces the economic burden of health-related costs associated with air pollution, such as respiratory diseases and cardiovascular conditions.

People can qualify for federal incentives like the solar investment tax credit by installing solar panels. These rewards may assist in reducing the cost of what has been originally paid for the installation of the solar panels, which boosts the economy, in both residential and commercial applications. Additionally, some governments provide grants, low-interest loans, and tax exemptions to encourage solar deployment, further reducing the financial barriers to adoption [40].

### 2.4. Types of photovoltaic cells

The development of PV cells has led to the creation of various types to address specific needs and challenges in solar energy generation. These include amorphous silicon, cadmium telluride, concentrated cells, dye-sensitized cells, and hybrid cells. These different types have been developed to improve efficiency, reduce costs, enhance flexibility, and adapt to diverse environmental conditions and applications. Despite these advancements, extensive ongoing research continues to focus on the development of new types of photovoltaic cells. The following subsections present a brief description of the distinct types of PV cells, and Fig. 4 shows a comparison of the highest verified solar cell efficiencies over time.

#### 2.4.1. Crystalline silicon

The crystalline silicon solar cell was one of the earliest created and

continues to be the most commonly used type. It still offers a very high efficiency and affordable price with respect to other emerging solar cell materials [42]. Silicon is the second most abundant element in the Earth's crust and is widely available. However, high-purity silicon production requires significant energy inputs, contributing to its environmental impact. The energy-intensive purification and crystallization processes result in a high carbon footprint. Additionally, the use of hazardous chemicals, such as hydrofluoric acid in wafer processing, poses environmental risks. Below is a brief overview of crystalline materials, including both monocrystalline and multi-crystalline silicon. Fig. 5 presents the structure and main components of a silicon solar PV module.

#### Monocrystalline silicon

Monocrystalline materials play a crucial role in the development of photovoltaic cells owing to their high efficiency, reliability, and maturity in the PV market. Most monocrystalline silicon is produced using the Czochralski process [1]. In this method, high-purity, semiconductor-grade silicon is melted in a crucible, typically made of quartz. Precise amounts of dopant impurities are introduced into the molten silicon to

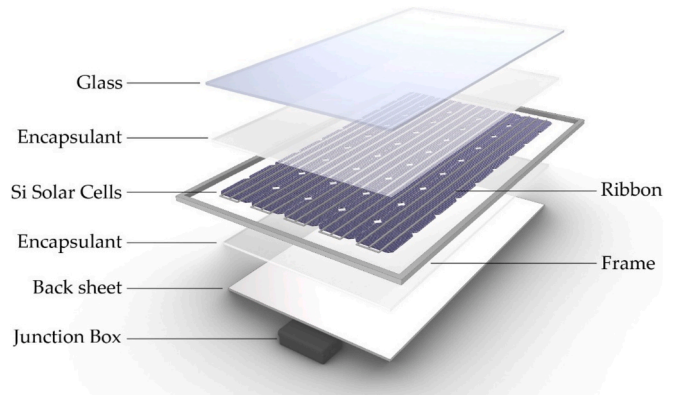

Fig. 5. Structure of a silicon-based solar PV module. ([], open access). Source: 45

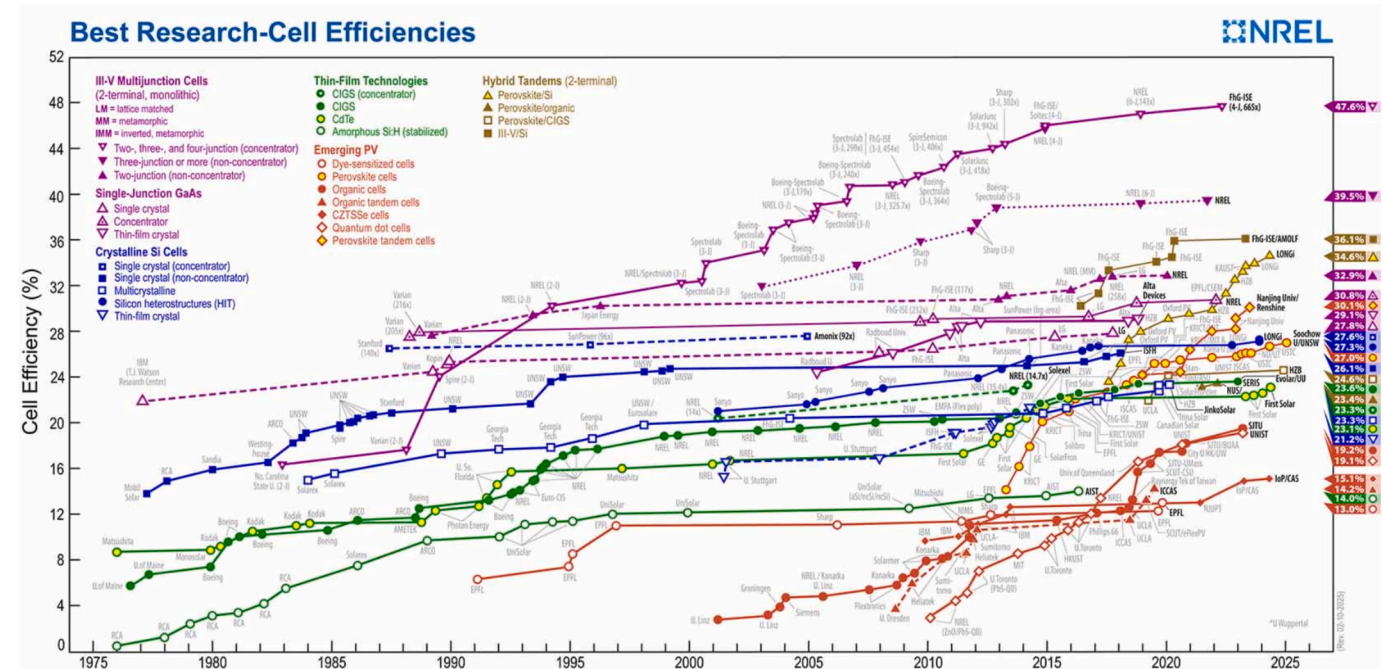

Fig. 4. The highest confirmed conversion efficiencies for research cells for a range of photovoltaic technologies. ([], open access). Source: 41

create n-type or p-type silicon, altering its electronic properties. A seed crystal, placed on a rod, is introduced into the molten silicon. The rod is then slowly pulled upward while rotating. By carefully regulating the temperature gradients, pulling rate, and rotation speed, a large, single-crystal cylindrical ingot can be extracted. To prevent instability in the melt, temperature and speed distributions throughout the crystal growth procedure are closely monitored. This procedure is usually conducted in an inert environment, like argon atmosphere or a quartz chamber.

#### Multi-crystalline silicon

Multi-crystalline solar cells are a cost-effective material for developing PV modules, but their efficiency is lower than monocrystalline cells and other advanced materials [43]. However, multi-crystalline cells have fewer defects related to metal contamination and crystal structure than monocrystalline cells. Multi-crystalline silicon is produced by melting silicon and allowing it to solidify, which causes the crystals to form in a fixed direction. This process results in a rectangular ingot of multi-crystalline silicon, which is then cut into blocks and ultimately sliced into thin wafers [44].

#### 2.4.2. Amorphous silicon

Silicon in its non-crystalline state is known as a-Si “amorphous silicon”. Having been available on the market for over two decades, this thin-film technology is one of the most established and proven. Although it is commonly found in pocket calculators, it is also utilized to power certain isolated facilities, buildings, and private residences. Along with Sharp and Sanyo, United Solar Systems Corp. (UniSolar) is still a leading manufacturer of a-Si solar cells. A one micrometer thick of thin coating of silicon material is vapor-deposited over a substrate made of glass or metal to produce a-Si panels. A-Si can be formed at an extremely low temperature as low as 75 °C, enabling sedimentation on plastic. At its most basic form, the p-i-n layer sequence is the only one present in the cell structure [46].

#### 2.4.3. Cadmium telluride

Cadmium telluride (CdTe) photovoltaics is the name given to a kind of PV technology that utilizes a thin semiconductor layer with the ability to absorb sunlight and turn it into electricity. The structure of a typical cadmium telluride PV solar cell is depicted in Fig. 6. Conventional solar cells, like crystalline Si-based, in multi-kilowatt systems are more expensive than cadmium telluride PV systems. Among solar energy technologies, CdTe PV has one of the lowest lifecycle carbon footprints, lowest water use, and fastest energy payback period. With an energy payback period of a year or less, CdTe enables quicker carbon reductions without causing temporary energy shortages. However, to reduce the environmental impact of cadmium toxicity, recycling CdTe modules at

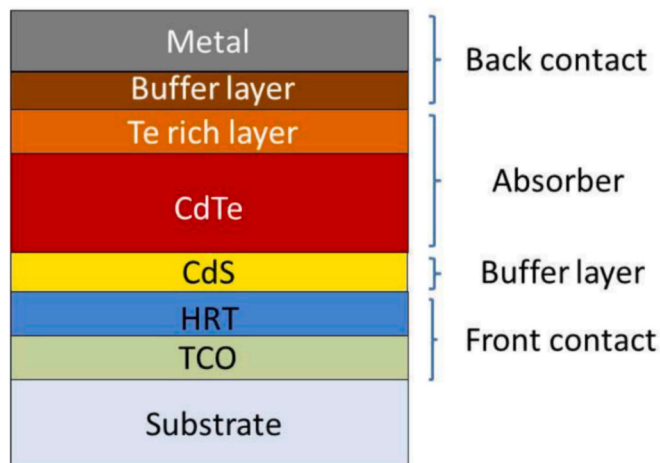

Fig. 6. Structure of a cadmium telluride solar cell. ([], open access).  
Source: 49

the end of their product lifecycle should be implemented [47,48].

#### 2.4.4. Copper indium gallium selenide

The compound known as copper-indium-gallium-selenide (CIGS) is one of the most interesting and controversial compounds in solar technology. A few CIGS companies, like Solyndra, NanoSolar, and MiaSolé, nearly became domestic names during the solar thin-film hype cycle. To produce these cells, a thin layer of copper, indium, gallium, and selenide is applied to a glass or plastic substrate, with electrodes placed on both the front and back to capture the current. Due to its high absorption coefficient, this material requires a much thinner layer than typical solar cells, as it effectively absorbs sunlight [50]. However, the availability of key elements poses challenges. Indium and gallium are scarce and primarily obtained as byproducts of zinc and aluminum production. Their limited supply and high demand in electronics may impact the long-term viability of CIGS technology. Additionally, the mining and processing of these elements generate significant environmental waste, and selenium can be toxic in high concentrations, requiring proper handling and disposal.

#### 2.4.5. Dye sensitized

Dye sensitized solar cells (DSSC) are the third generation of solar cells [51]. Because of the way this new form of sophisticated solar cell imitates the way light energy is absorbed by nature, artificial photosynthesis can be compared to it. DSSC was developed in 1988 at École Polytechnique Fédérale de Lausanne, in Switzerland, by Michael Grätzel and Brian O'Regan. In [52], they developed a DSSC using low-cost processes and low-to-medium-purity materials, achieving commercially viable efficiency. The cell consists of a 10- $\mu$ m-thick titanium dioxide film coated with a charge-transfer dye, optimizing light harvesting and photon-to-current conversion efficiencies (over 80 %). With an overall energy conversion efficiency of 7.1–7.9 % under simulated solar light and 12 % in diffuse daylight, alongside high current densities (>12 mA/cm<sup>2</sup>) and stability over five million cycles, the DSSC offers low-cost and practical scalability.

#### 2.4.6. Gallium arsenide

The two fundamental components of gallium and arsenic combine to form gallium arsenide (GaAs). These two separate components combine to generate the aforementioned chemical, which has a number of intriguing properties. The semiconductor gallium arsenide has higher electron mobility and saturation electron velocity than silicon. The direct band gap is another unique feature of gallium arsenide, which indicates a substance with effective light emission. GaAs has a zinc blende crystal structure and a III-V direct bandgap semiconductor [53].

#### 2.4.7. Perovskite

Perovskite solar cells (PSCs) have quickly become a highly promising PV technology, mainly due to their superior optoelectronic properties and simple construction process [54,55]. The configuration of a perovskite PV cell is shown in Fig. 7. Among the various third-generation photovoltaic devices, PSCs have received significant attention from the scientific community. Introduced in 2009, PSCs were developed based on DSSC technology as a potential renewable energy solution. In these cells, the primary material is perovskite, an organic-inorganic hybrid compound with an ABX<sub>3</sub> crystalline structure that serves as the active light-harvesting layer. In this structure, “A” and “B” represent two different cations, while “X” is an anion. Specifically, “A” can be calcium, cesium, methylammonium, or formamidinium; “B” can be titanium, lead, or tin; and “X” can be chlorine, bromine, or iodine.

In contrast to conventional solar cells, PSCs offer intrinsic advantages, such as superior optical absorption, higher carrier mobility, and longer carrier diffusion lengths, which have led to considerable enhancements in conversion efficiency and attracted considerable interest from researchers [56]. Despite their rapid development and impressive efficiency gains, PSCs face significant technical and environmental

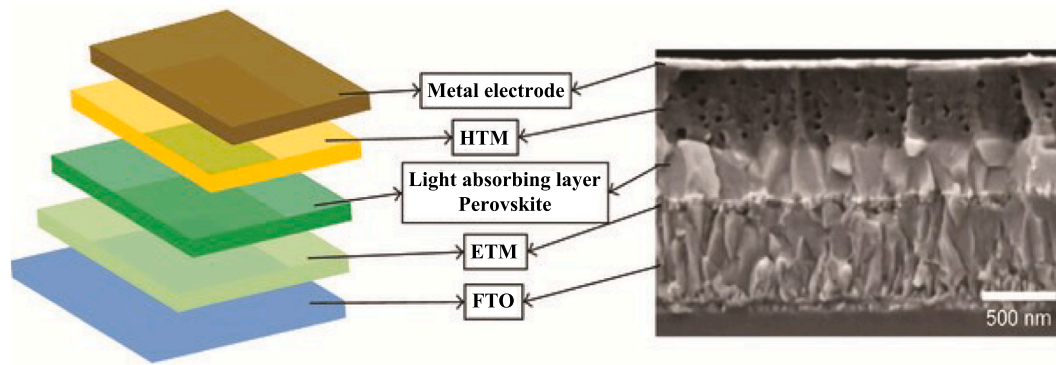

Fig. 7. Structure of a perovskite solar cell. ([], open access).  
Source: 61

challenges that hinder large-scale deployment [57,58]. One of the most critical issues is long-term stability, as PSCs are highly susceptible to degradation when exposed to moisture, oxygen, UV radiation, and elevated temperatures. This instability necessitates advanced encapsulation strategies and the development of more resilient perovskite formulations. Additionally, the widespread use of toxic lead in high-performance PSCs poses environmental and health concerns, particularly regarding lead leakage from deteriorating modules. While lead-free perovskites, such as tin-based alternatives, are being explored, they currently suffer from lower efficiencies and reduced stability. Furthermore, PSC production processes involve the use of solvents and chemicals that may have environmental implications, necessitating the development of greener manufacturing approaches to minimize their ecological footprint.

Beyond technical concerns, the commercialization of PSCs faces multiple economic and industrial barriers [59,60]. A primary challenge is scalability, as translating lab-scale efficiencies to large-scale commercial modules remains difficult due to non-uniform crystal formation and defects such as pinholes. Maintaining high efficiency over large-scale production requires optimized fabrication techniques to ensure consistency and reproducibility. Additionally, manufacturing reliability remains a concern, as slight variations in processing conditions can significantly impact performance. Another hurdle is encapsulation and durability, as PSCs degrade faster than conventional silicon solar cells, necessitating robust protective coatings that add complexity and cost. Moreover, regulatory hurdles exist due to the presence of lead, which could impact approvals for widespread use. While research into lead-free alternatives continues, these options have yet to match the performance of lead-based PSCs. Lastly, market competition with well-established silicon PV technology poses an economic challenge, as PSCs must prove their long-term viability and cost-effectiveness to gain commercial acceptance.

#### 2.4.8. Organic solar cells

Organic solar cells (OSCs) mark a notable breakthrough in solar technology, featuring carbon-based materials such as polymers and small molecules that serve as organic semiconductors. This sets OSCs apart from conventional inorganic PV cells. The distinctive attributes of these materials, including flexibility, semitransparency, and low-temperature processability, enhance their versatility for diverse applications, expanding their use beyond traditional solar panels. The growth of OSC development began after the development of several organic semiconducting polymers. Harvesting a significant number of photons is usually achievable with an ideal semiconducting polymer that has a low band gap [62]. However, organic semiconducting polymers possess a higher exciton binding energy compared to inorganic semiconductors, which can affect the overall performance of the PV. An OSC consists of various layers, including a substrate with a transparent conductive oxide, a hole-transporting layer, an active layer, an electron-

transporting layer, and a cathode (see Fig. 8).

Despite their advantages, OSCs face significant technical and environmental challenges that hinder their large-scale adoption [63]. One major limitation is their relatively low power conversion efficiency compared to silicon-based solar cells, as well as their rapid degradation under environmental exposure, including UV radiation and oxygen, which reduces their operational lifespan. Similar to PSCs, stability issues have prompted research into more robust encapsulation techniques and material modifications to improve durability [64]. Additionally, the production of certain organic semiconductor materials involves the use of hazardous solvents and complex synthesis processes, raising environmental and safety concerns.

#### 2.4.9. Hybrid solar cells

A hybrid solar cell merges both organic and inorganic semiconductors. Organic components used in hybrid photovoltaics are conjugated polymers that absorb sunlight and act as givers and transfer holes. In hybrid cells, inorganic materials serve as the structure's collector and electron transporter. The photoactive layer of hybrid solar cells is created by combining an organic substance with a material that has a high electron transport capacity. A heterojunction-type photoactive layer is formed when combining two materials, with a higher energy conversion efficiency than when individual material is used alone. One of the components serves as both an exciton donor and a

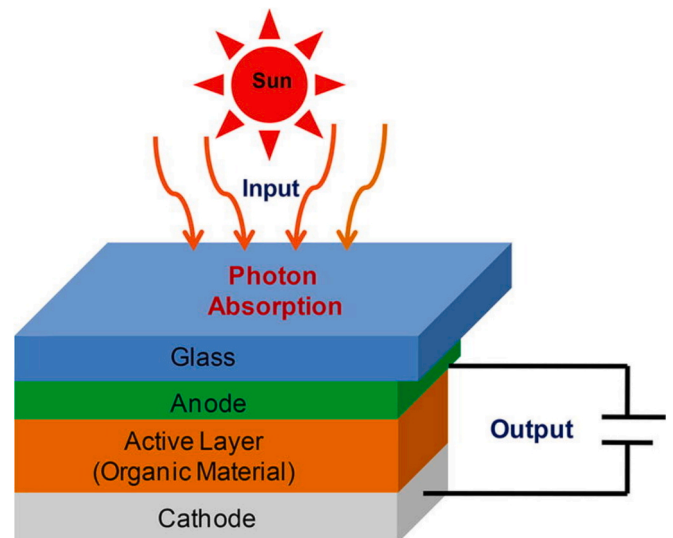

Fig. 8. Organic solar cell structure. ([], with permission number 5931810016944).  
Source: 65

photon absorber. Exciton dissociation at the junction is facilitated by the other substance. Once an exciton formed in the donor is delocalized onto a donor–acceptor complex, the charge is transferred and subsequently separated. The energy compensated between the donor and acceptor's lowest unoccupied molecular orbital, or conduction bands, supplies the energy needed to split the exciton. A percolation network is used to move the carriers to the appropriate electrodes following dissociation [66,67].

#### 2.4.10. Biohybrid

Biohybrid solar cells are similar to hybrid cells as they both combine inorganic and organic materials, while biohybrid cells specifically incorporate biological elements (photosystem I). Fig. 9 displays the working principle of a biohybrid PV based on the photosynthetic apparatus components [68]. An example of developing a biohybrid solar cell is presented by Gizzie et al. [69]. To improve the overall energy conversion, researchers replicated the natural process of photosynthesis by utilizing photosystem I, a light-sensitive protein complex located in the thylakoid membrane. The photosystem in biohybrid solar cells is composed of several layers. It collects photon energy, transforms it into chemical energy, and then uses that energy to produce a current that flows through the cell. The photosystem I complexes, which are injected and accumulated in the gold layer for several days, are the only non-organic substances present in the cell that differ from those found in other solar cells. Days later, the photosystem becomes visible and takes the form of a thin layer. This thin sheet facilitates and enhances the conversion of energy. However, the biohybrid cell is still in the experimental stage.

#### 2.4.11. Concentrated solar cells

A type of photovoltaic technology is called concentrator photovoltaics (CPV), which accomplishes the same conversion of light energy into electrical energy as traditional PV technology. There are various CPV designs, some of which are distinguished from one another by the

concentration factor, commonly known as high and low concentrated PVs. In contrast to ordinary PV systems, it concentrates sunlight onto effective multi-junction solar cells using lenses and curved mirrors to enhance the overall performance of solar PV [70,71].

#### 2.4.12. Buried contact

A buried contact solar cell, utilizing laser-etched grooves, serves as the foundation for high-efficiency commercial solar cell technology. Many of the drawbacks of screen-printed contacts are eliminated by buried contact technology, which enables buried contact solar cells. The metal is buried inside a silicon solar cell's laser-formed groove, which is a crucial component of the device's high efficiency. This permits a high metal aspect ratio of height to breadth. Thus, a great metal contact aspect ratio eliminates the need for a broad metal strip on the top surface and permits the application of a great volume of metal in the contact finger. Consequently, a high metal aspect ratio maintains a high transparency while enabling a huge number of metal fingers that are closely spaced [72].

#### 2.5. Balance of the PV system

The PV BOS “balance-of-system” refers to the equipment that channels the DC electricity produced by PV panels through the inverter system, which transforms it into alternating current. BOS often refers to all components of a solar system except the modules. This covers the ground fault detectors, fuses, switches, enclosures, cables, and wires in addition to the inverters and racking. BOS is an integral part of all types of solar applications. Around 10 %–50 % of solar installation and purchase expenses are included in BOS components, which also cover the majority of maintenance needs [73]. In principle, BOS components can enhance PV systems, stabilize costs, and improve efficiency. Individualized planning can result in a BOS environment that is both economical and energy efficient, which can be performed as shown below:

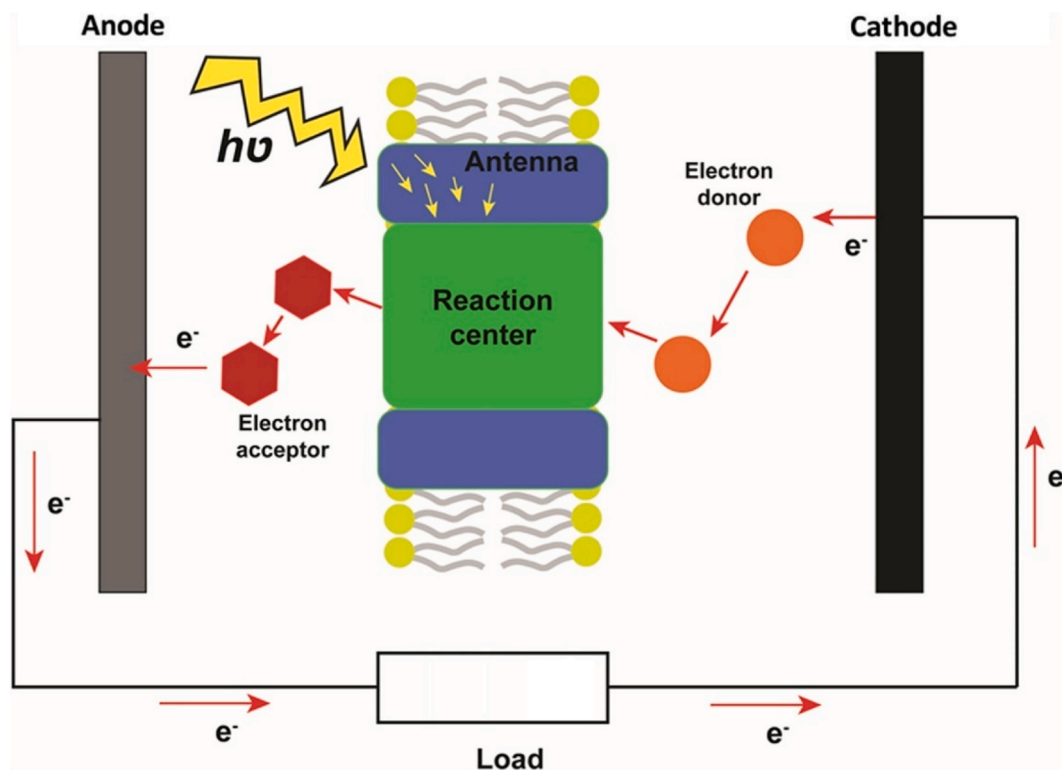

Fig. 9. Schematic diagram of a biohybrid solar cell's operation. ([], with permission number 5932310089785).

Source: 68

- Assess solar power or photovoltaic potential daily of a location through solar mapping.
- Examine utility bills with a potential customer to assist them in comprehending how much they pay per kilowatt-hour, as well as energy usage and changes.
- Examine and suggest insulation to improve energy efficiency and qualify for rebates.
- Based on the best southern exposure, estimate and compare the prices of installing ground-mounted and rooftop solar PV panels.
- Compute solar system installation methods to ascertain which balance-of-systems components are required and which are optional.
- Demonstrate short-term value by deducting the total from the installation cost of solar PV and adding monthly utility savings to eligible rebates or incentives.
- Rely on experience to suggest BOS operations that are smooth and require little maintenance.
- Incorporate the most advanced and proven technologies available in the market.

### 3. Developments of solar photovoltaic

Like many other historical discoveries, the history of photovoltaics started by coincidence in 1839. The following subsections will explore some of the key figures, events, and facts that have shaped photovoltaics, highlighting the evolution of this technology through history. Table 2 summarizes the historical key milestones in solar PV by year.

#### 3.1. The photovoltaic effect, 1839–1887

The earliest stage of solar PV involved exploring the fundamental properties of PV materials. In 1839, French physicist Alexandre Edmond

**Table 2**  
Key technological milestones in solar photovoltaic development by decade.

Decade(s)	Key milestones
1830s-1880s	<ul style="list-style-type: none"> <li>- 1839: Alexandre Edmond Becquerel discovered the photovoltaic effect.</li> <li>- 1873: Willoughby Smith observed the PV effect in selenium.</li> <li>- 1876: William G. Adams and Richard Day demonstrated the PV effect in selenium-platinum junction.</li> <li>- 1883: Charles Fritts developed the first selenium solar cell.</li> </ul>
1900s-1930s	<ul style="list-style-type: none"> <li>- 1905: Albert Einstein provided a theoretical explanation of the PV effect.</li> <li>- 1921: Einstein received the Nobel Prize for his work on the photoelectric effect.</li> <li>- 1918: Jan Czochralski developed a method for producing monocrystalline silicon. 1932: Discovery of the PV effect in cadmium sulfide.</li> </ul>
1950s-1960s	<ul style="list-style-type: none"> <li>- 1954: Bell Labs developed the first practical silicon solar cell (4.5 % efficiency).</li> <li>- 1958: Vanguard I became the first satellite powered by solar cells.</li> <li>- 1963: Sharp developed the first practical PV module.</li> <li>- 1964: First large-scale PV field (470 W) used in the Nimbus space project.</li> </ul>
1980s	<ul style="list-style-type: none"> <li>- 1980s: Crystalline silicon solar cells achieved efficiency greater than 10 %.</li> <li>- 1982: First megawatt-scale PV power station installed in California, USA.</li> <li>- 1989: Development of advanced inverters for grid-connected PV systems.</li> </ul>
1990s	<ul style="list-style-type: none"> <li>- 1990: United Solar Systems Corporation was founded for large-scale solar cell production.</li> <li>- 1995: Rapid growth in global PV installations due to declining costs and improved efficiency.</li> <li>- 1999: Industry shifts focus toward high-efficiency and thin-film technologies.</li> </ul>
2000s	<ul style="list-style-type: none"> <li>- 2001: HELIOS solar-powered aircraft reached a record altitude of 96,863 ft.</li> <li>- 2003: "Solarpark Hemau" became the world's largest PV plant (4 MW, Germany). 2004: Germany's Renewable Energy Law (EEG) accelerated large-scale solar deployment.</li> </ul>

Becquerel discovered the photovoltaic effect, demonstrating that light could increase electrical conductance in an electrolyte-metal electrode system. In 1873, Willoughby Smith identified the PV effect in selenium, followed by William G. Adams and Richard E. Day in 1876, who demonstrated a selenium-platinum junction generating electricity when exposed to light. This led to the development of the first selenium solar cell in 1877, later refined by Charles Fritts in 1883. In 1887, Heinrich Hertz observed that ultraviolet light could affect electrical conduction, further advancing PV research [74].

#### 3.2. Theoretical interpretation and development of solar cells, 1905–1932

Albert Einstein provided a theoretical explanation of the photovoltaic effect in 1905, earning the Nobel Prize in 1921 for his contributions. In 1918, Polish scientist Jan Czochralski developed a method for producing monocrystalline silicon, a key material for modern solar cells. In 1932, researchers first observed the PV effect in cadmium sulfide (CdS), which remains widely used in solar technology today [74].

#### 3.3. Extensive space research, 1953–1969

In 1953, Dan Trivich conducted theoretical assessments on solar spectrum wavelengths and PV materials. The first practical silicon solar cell was developed by Bell Labs in 1954, achieving 4.5 % efficiency, later improved to 6 %. In 1955, Western Electric began commercial solar cell production [75–78]. The first solar-powered satellite, Vanguard I, was launched in 1958 and operated for eight years. Subsequent advances led to improved efficiency: Hoffman Electronics introduced 8 % efficiency cells in 1957, followed by 9 % in 1958 and 14 % in 1960. In 1962, Bell Labs launched Telstar, the first commercial telecommunications satellite powered by solar cells. Sharp Corporation developed the first practical silicon-based PV module in 1963. By 1966, a 1 kW photovoltaic array was deployed in space, marking a significant milestone for large-scale solar applications [79].

#### 3.4. First large utility-scale PV systems, 1980–1989

During the 1980s, solar PV technology saw significant advancements in efficiency and cost reduction, enabling larger solar installations. Crystalline silicon cells dominated, reaching efficiency rates above 10 % by the decade's end. Improved inverters facilitated better grid integration, while policy support, such as the U.S. Public Utility Regulatory Policies Act of 1978, encouraged private investment in renewable energy projects. These developments laid the foundation for large-scale solar adoption [80,81].

#### 3.5. Large-scale solar cell manufacturers, 1990–1999

The 1990s saw major advancements in solar cell manufacturing. In 1990, United Solar Systems Corporation was founded as a joint venture between Energy Conversion Devices Inc. (ECD) and Canon Inc. to produce solar cells. Siemens also expanded its presence by acquiring ARCO Solar and establishing Siemens Solar Industries [79,82]. Companies like Siemens and Sharp focused on improving crystalline silicon solar cells, enhancing efficiency, and reducing costs [83,84]. By 1991, manufacturers, including Kyocera, explored thin-film solar cells for cost reduction and broader applications [85]. Government incentives in Japan and Germany further boosted solar adoption, increasing production capacity [86]. Between 1994 and 1999, the industry experienced rapid growth. By 1995, declining costs and efficiency improvements drove global solar installations. Companies like Sanyo scaled up production and invested in new technologies [87]. By 1999, large-scale manufacturers had matured, leveraging efficiency gains and strategic partnerships to solidify their role in the renewable energy transition [85].

### 3.6. Utility-scale photovoltaic power plants, 2000–2009

The early 2000s saw rapid growth in utility-scale photovoltaic (PV) power. Capital mergers in Germany led to major PV firms, while Japanese manufacturers like Sharp and Kyocera significantly increased production between 2000 and 2001, supplying modules with peak power comparable to Germany's annual consumption—Europe's most attractive market [88]. On August 13, 2001, NASA and AeroVironment's HELIOS solar-powered aircraft set a record altitude of 96,863 ft after years of research and testing [89]. Between 2002 and 2003, Germany saw the construction of several large PV plants. On April 29, 2003, the "Solarpark Hemau" in Bayern, with a peak capacity of 4 MW, became the world's largest PV facility at the time. By 2004, multiple 5 MW systems were built under Germany's "EEG" renewable energy law, further accelerating large-scale PV deployment [90].

## 4. Current trends, innovations, and challenges

### 4.1. Efficiency enhancements in solar cells

Scientists are always finding new ways to boost solar cell efficiency because, despite the fact that solar energy has not yet realized its full potential, solar cells are now more efficient. In 2010, the average efficiency of commercial Si-based solar cells was 15 % [44]. Nowadays, these cells typically have average efficiencies of around 22 %, with some exceeding 25 %. Notably, Oxford PV has proven that mixed perovskite and Si-PV materials can exhibit record-breaking efficiency of up to twenty-eight percent in laboratory settings. A recent cost-effective polymer-glass stack encapsulation technique has allowed PSCs to tolerate typical working conditions; however, stability and durability have remained a serious concern. Even though PSCs haven't been made widely available, yet their considerable cost and performance benefits will likely shape the direction of the solar energy industry going forward [91]. Additionally, some new research studies have reported even higher PV cell efficiencies, but are still not commercially available due to some challenges such as the high capital cost of such cells [77]. There are several causes that have contributed to this rise in efficiency, including the following:

- Better cell design: Scientists have created new solar cell architectures that transfer light from the sun more effectively into electrical power.
- Novel materials: Novel materials that can be utilized to produce solar cells with higher efficiency include perovskites and organic semiconductors.

- Improved manufacturing procedures: Improvements in manufacturing procedures have produced solar cells that result in more reliable products of higher caliber.

### 4.2. Innovative solar PV technologies

#### 4.2.1. Bifacial photovoltaic panels

Bi-facial photovoltaic panels represent a remarkable advancement in solar energy technology, offering notable advantages over conventional mono-facial panels [92,93]. Unlike mono-facial systems, bi-facial PVs can receive sunlight from their front and rear sides, significantly boosting their energy generation potential (see Fig. 10). This dual-sided design not only enhances overall efficiency but also proves more effective under varying conditions such as partial shading, low solar radiation, or snowy environments. Research has consistently highlighted their superior performance, showing that bi-facial panels generate higher energy yields, require less space, and offer greater potential for reducing greenhouse gas emissions. Moreover, they demonstrate improved efficiency when integrated with cooling mechanisms, solar trackers, or in climates impacted by snow or climate change. Their ability to operate efficiently in diverse scenarios, combined with a lower leveled cost of electricity and greater adaptability to space-constrained locations, makes bi-facial PV panels a more sustainable and cost-effective choice for grid-connected solar systems. This combination of technical and financial benefits positions them as a transformative solution for the future of solar energy.

Despite their advantages, bi-facial photovoltaic panels face several challenges that may limit their widespread deployment [94,95]. The performance of these systems is highly dependent on site-specific conditions such as ground reflectivity (albedo), panel height, and tilt angle, which require careful optimization to maximize energy gains. Additionally, the initial capital cost of bi-facial systems is generally higher than that of conventional mono-facial panels due to more complex mounting structures and installation requirements. Accurate performance prediction and long-term reliability assessments are still evolving, posing uncertainties for investors and developers. Moreover, soiling and rear-side shading can significantly reduce their expected performance if not properly managed.

#### 4.2.2. Solar shingles

Solar shingles are roofing materials that integrate solar cells into a building's structure. They are made to resemble traditional roofing materials, such as clay or asphalt tiles, and contain either c-Si or thin-film solar cells embedded in their surface. Solar shingles are a favorable advancement in the solar PV sector because they improve the

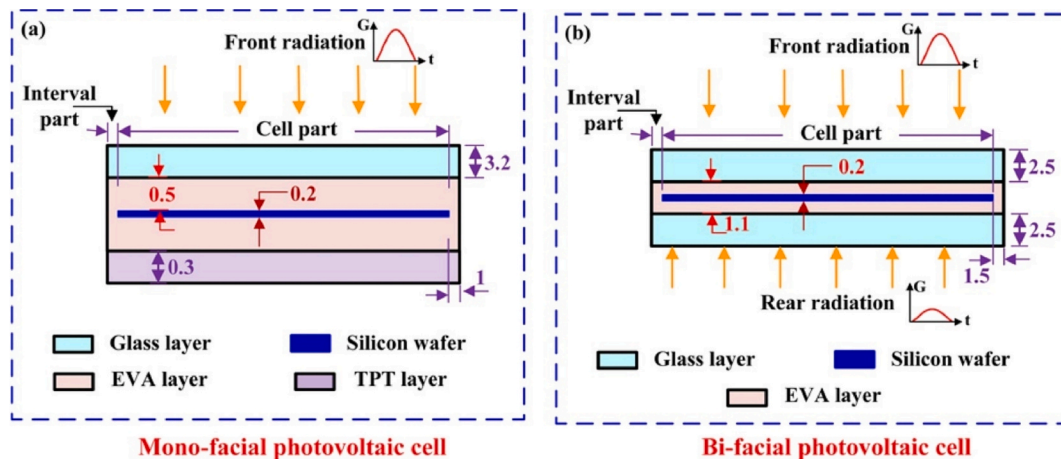

Fig. 10. Schematic diagram of (a) mono-facial and (b) bi-facial PV panels. ([], open access). Source: 92

feasibility and aesthetics of integrating solar energy into residential and commercial structures [96,97], as illustrated below:

- **Aesthetic appeal:** Unlike typical solar panels, which have a bulky appearance, solar shingles are aesthetically pleasing and integrate perfectly with a building's overall architecture.
- **Space efficiency:** They are appropriate for homes with limited roof space since they maximize space utilization by acting as both energy generators and roofing materials.
- **Increased adoption:** The appearance of standard solar panels may put off homeowners, but solar shingles make solar energy more appealing and accessible.
- **Grid resilience:** By producing power at the site of demand and lowering transmission losses, they help to maintain grid resilience.
- **Environmental advantages:** By minimizing GHG emissions and decreasing dependence on fossil fuels, solar shingles support the production of clean, sustainable energy.

However, despite their aesthetic and functional advantages, solar shingles face several challenges that hinder their widespread adoption. One of the main limitations is their relatively high upfront cost compared to conventional solar panels, primarily due to the complexity of manufacturing and installation. Additionally, the efficiency of solar shingles is generally lower than that of standard photovoltaic modules, which may result in lower energy yields. Their integration also requires specialized labor and may complicate roof maintenance or repairs.

#### 4.2.3. Transparent solar cells

Solar windows, also referred to as transparent solar panels or photovoltaic windows, are cutting-edge building materials that use sunlight to create electricity while letting visible light in. Transparent PV cells are integrated into the glass or window frame [98]. These cells let through visible light while absorbing certain light wavelengths, mostly in the ultraviolet and near-infrared range. They make use of substances like organic photovoltaic materials and transparent conductive oxides [99]. The transparent PV cells in the solar window capture solar energy and turn it into electrical power when sunlight touches them. The building's electrical appliances can subsequently be powered by this electricity, or sent to the grid. Solar windows provide a more sustainable and effective way to harness solar energy while maintaining natural light and aesthetic appeal, making them a viable alternative to conventional windows. This makes them a potential choice for energy generation in buildings [100]. To improve glass's capacity to capture solar energy, light-selective coatings are occasionally put on its surface. These coatings aid in capturing sunlight and directing it towards the glass's embedded transparent solar cells [101].

The deployment of solar windows is accompanied by several technical and economic challenges. Their energy conversion efficiency is generally lower than that of conventional PV panels, as they must balance transparency with power generation. Additionally, the specialized materials and fabrication techniques required for transparent photovoltaic cells increase production costs. Issues related to long-term durability, such as weathering effects, color stability, and maintenance, also need to be addressed. Furthermore, retrofitting existing buildings with solar windows can be expensive and structurally complex, limiting their immediate applicability to new constructions or large-scale projects.

#### 4.2.4. Solar tracking

The solar tracker is a sophisticated device designed to optimize the positioning of photovoltaic panels, ensuring they remain perpendicular to sunlight throughout the day and thereby maximizing energy capture [102,103]. By continuously adjusting the panels to follow the sun's trajectory, solar trackers enhance the efficiency of solar energy systems. Previous research demonstrates that solar trackers can capture 20 to 50 % more solar energy compared to fixed-angle photovoltaic systems, with

specific performance improvement influenced by geographic location, weather conditions, and the time of year [4,104]. This significant increase in energy capture underscores the crucial role of solar tracking in enhancing the overall viability and effectiveness of solar energy technologies, especially in locations with high solar irradiance or variable sunlight angles. Solar trackers are broadly classified into single and dual axes. The former trackers follow the sun's movement along a single plane, such as east to west, and are usually utilized in large-scale PV installations due to their cost-effectiveness and relatively simple design. On the other hand, dual-axis trackers allow panels to move along two planes, both horizontally and vertically, enabling precise alignment with the sun at all times. These systems are particularly beneficial in applications where maximizing energy capture is a priority, as they can adapt to seasonal changes in the sun's altitude. While dual-axis trackers offer higher energy gains, they are generally more expensive and require additional maintenance compared to single-axis systems. The choice between these systems often depends on site-specific factors such as solar resource availability, land constraints, and economic considerations.

#### 4.2.5. Maximum power point tracking

In addition to improvements in solar cell efficiency and structural innovations such as bifacial panels and solar trackers, advancements in power electronics and control algorithms have significantly contributed to the effective utilization of solar PV systems. One of the most critical technologies in this context is maximum power point tracking (MPPT) [105]. MPPT controllers continuously adjust the electrical operating point of the photovoltaic modules to ensure that they deliver the maximum possible power, regardless of variations in sunlight intensity, temperature, shading, or load conditions. This dynamic optimization increases the overall efficiency and economic viability of solar energy systems, particularly in environments characterized by fluctuating weather patterns or partial shading effects.

#### 4.2.6. Photovoltaic-based hydrogen production

One promising area of research gaining significant attention is the integration of solar PV systems with water-splitting units for green hydrogen generation [106]. Green hydrogen, produced from RESs like solar power, is increasingly considered a key solution for decarbonizing various sectors and transitioning to a sustainable energy future [107,108]. Fig. 11 illustrates the main concept of green hydrogen production using photovoltaic-driven water splitting. This integration offers multiple advantages, with one of the most critical being the efficient utilization of excess electricity generated by solar PV systems. Instead of wasting excess energy, it can be stored as hydrogen, a versatile energy carrier that addresses the intermittency of RESs and ensures a steady energy supply. Hydrogen enables energy storage on a large scale, balancing supply and demand, and providing resilience to the energy grid. Beyond energy storage, hydrogen plays a pivotal role in diverse applications, further emphasizing its importance. It is a clean fuel that can power fuel cell vehicles, offering zero-emission transportation solutions. In the industrial sector, hydrogen is used as a feedstock for processes like ammonia production and refining. Furthermore, it holds potential in heating applications, replacing natural gas in residential and commercial heating systems. Green hydrogen also enables the decarbonization of hard-to-abate sectors such as steel manufacturing and aviation, where direct electrification is challenging [109].

Despite its significant environmental and technical benefits, the economic viability of photovoltaic-based hydrogen production remains a key challenge. Currently, the cost of green hydrogen production via PV-driven water splitting is relatively high compared to hydrogen produced from fossil fuels (commonly referred to as grey hydrogen) or blue hydrogen (produced from natural gas with carbon capture). The high capital cost of electrolyzers, and PV systems, and the limited economies of scale contribute to this cost disparity. Additionally, factors such as PV electricity price fluctuations, electrolyzer efficiency, and operational

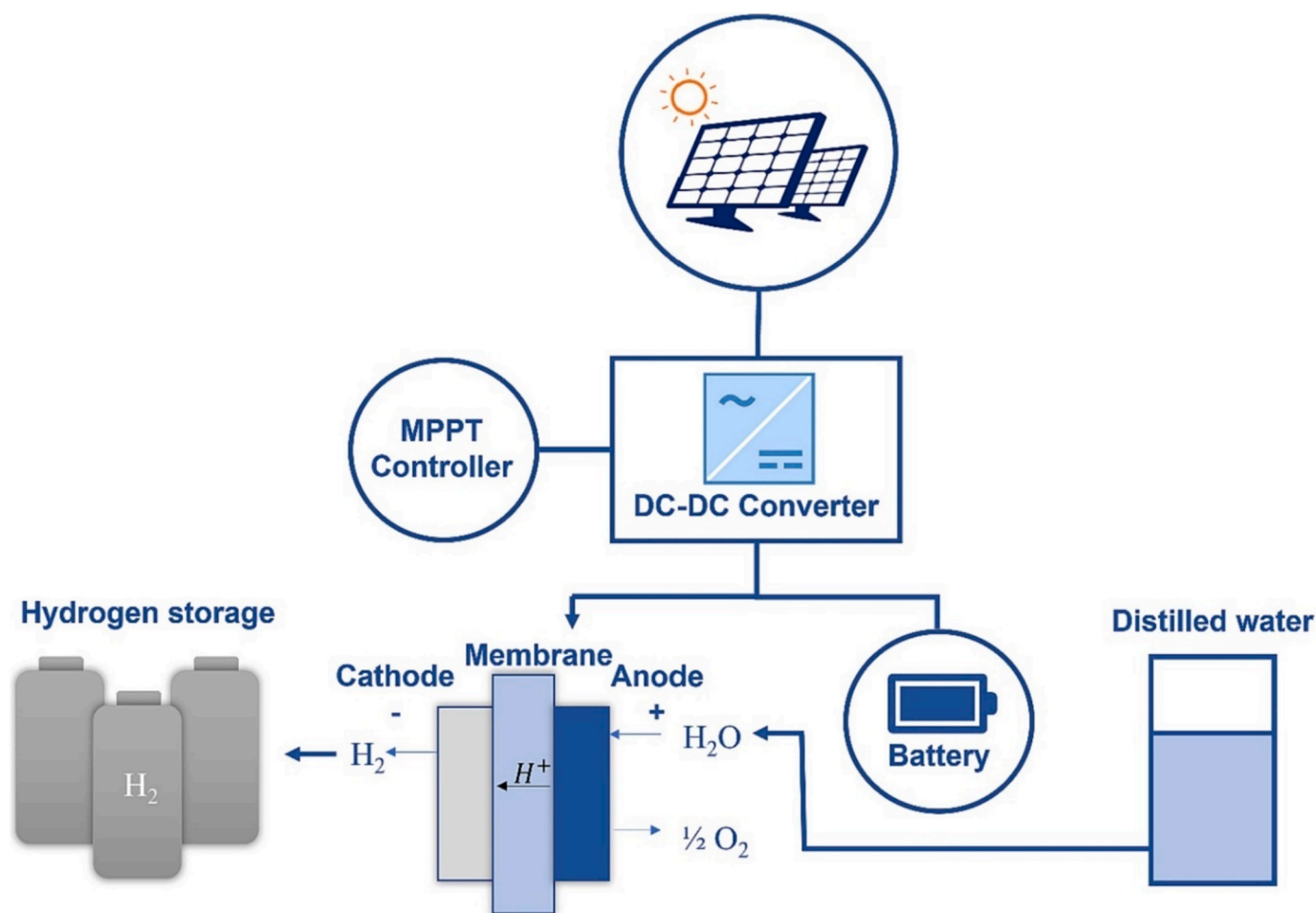

Fig. 11. Schematic diagram of a photovoltaic-driven hydrogen production system. ([], with permission number 5931390106178).

Source: 106

expenditures further affect the economic feasibility. However, ongoing technological advancements, increasing electrolyzer capacities, and declining costs of solar PV modules are progressively narrowing this gap. Several studies project that with continued policy support, scaling up of infrastructure, and technological improvements, PV-based hydrogen production could become cost-competitive within the next decade, particularly in regions with high solar irradiance. Therefore, while it is not yet economically viable on a large scale, it holds promising potential for the future energy market.

#### 4.3. Technological challenges

Current market data indicates that the available PV technologies achieve conversion efficiencies of less than 23 %, highlighting the critical need for further advancements in this sector. Such enhancements are essential not only to improve the performance of solar energy systems but also to enhance their competitiveness against alternative energy sources. Continuous research and development efforts must be directed towards optimizing material properties, improving manufacturing processes, and integrating innovative technologies to elevate the overall performance of PV systems in a rapidly evolving energy landscape [110]. The efficacy of PV systems can be influenced by multiple meteorological factors, such as wind, ambient temperature, dust, solar radiation, and the presence of clouds. For example, the regions that have sunny weather can provide high solar energy output; however, these areas are usually high in dust accumulation [111,112]. The PV cell temperature is another crucial factor that significantly

influences the PV cell performance. PV panels tend to produce less electricity when their cell temperatures rise. PV system performance can be greatly improved by using effective cooling and heat management strategies [113,114].

#### 4.4. Economic considerations and market dynamics

According to a technology-driven life-cycle perspective, industries reliant on advanced technologies follow an unpredictable path due to the intricate relationships between market and competitive forces. Additionally, the survival of businesses heavily relying on funding and revenue from new technologies remains uncertain. Standard-setting is the main focus of the industry's growth phase, after which the winners turn their attention to increasing output and cutting costs. Customers select technologies at this point, and innovation focuses on scaling up production methods to reduce costs per unit and recover financial commitment. During this growth phase, there are two stages: production and market positioning, as well as supply chain establishment. The difficulty of transitioning from demonstration to scaled manufacturing that permits economies of scale and competitive price is a symbol of the technology transfer gap. Many external players are frequently required to provide bridging for the gaps that are pertinent to these stages. Similar to the emerging phase, funding is necessary for scaling and market positioning. The technology is typically more attractive but going from a demonstration or pilot plant to production typically requires bigger sums of money.

PV electricity still accounts for only a small percentage of installed

renewable energy capacity. As the sector transitioned from demonstration to production and market positioning, gaps in technology became evident. These gaps include technology transfer and market transfer. Cost barriers from demonstration to scalability have hindered technology transmission, while cheaper electricity generation options, such as natural gas, have impeded market transfer. However, renewable energy sources like biomass and wind are nearly as competitive as natural gas. Notably, the Japanese government's actions in the 1980s significantly reduced the interest gap, which was further narrowed by the German government's substantial policy and subsidy commitments to photovoltaic technology in the 1990s [115].

Eventually, the expansion of the PV sector slows, prompting businesses to shift their focus to pricing strategies, gaining market share, and consolidation. Acquisitions and price competitiveness become defining characteristics of this advanced stage. A key milestone is establishing PV technology as the industry standard. Advancing from the market positioning stage, this phase requires addressing a significant diffusion gap, which can be chronological, geographical, or both. Sustaining and strengthening the market position of PV technologies involves moving beyond short-term, subsidy-driven adoption or localized success. Achieving spatial expansion may depend on strategically positioned partnerships, while temporal growth requires fostering long-term collaborations.

## 5. Implications and future directions

Manufacturing materials and modules that reduce the BOS "balance of system" costs, which constitute the majority of installed system expenses and offer the greatest potential for cost reduction, is crucial for the continued growth of the solar PV industry. Using less expensive solar cell materials, minimizing material usage, reducing cell manufacturing costs, and increasing cell efficiency are key strategies to achieve this. In order to achieve more notable cost savings and performance gains, R&D is constantly making progress in both established and developing technologies. The photovoltaic technology portfolio is anticipated to remain diverse in terms of technologies. First-generation technologies still account for most of the world's yearly production, having been developed throughout the whole PV value chain. Perovskite and tandem technologies also present compelling views, but only in the long run because of unresolved issues with durability and cost [91,116].

Technology, deployment, investment, grid integration, and socioeconomic factors are key drivers of the global energy transition, which aims to reduce carbon dioxide (CO<sub>2</sub>) emissions. This transition moves away from fossil fuels, which contribute to climate change, towards clean and renewable energy. Part of this worldwide energy transition is the constant increase in solar photovoltaic power generation. Renewable energy is essential to achieving the Paris Agreement as well as lowering air pollution, enhancing health and wellbeing, and enabling universal access to affordable energy. The International Renewable Energy Agency (IRENA) has released a study outlining solutions to accelerate deployment and completely realize the tremendous potential of solar photovoltaics worldwide until 2050 [117].

Despite the growing adoption of solar PV systems, the high cost of associated energy storage solutions remains a significant barrier to their large-scale deployment. Several potential strategies can be implemented to address this challenge. For example, advancements in battery technologies, such as lithium-ion, flow batteries, and emerging solid-state batteries, are expected to reduce costs through economies of scale and material innovations. Additionally, the implementation of hybrid storage systems combining different storage technologies can optimize performance and reduce overall costs. The development of second-life battery applications, where retired electric vehicle batteries are repurposed for stationary energy storage, also offers a sustainable and economical solution. Furthermore, policy-driven approaches, including government incentives, tax credits, and energy storage mandates, can play a vital role in lowering the financial burden on investors and

accelerating the deployment of solar energy storage systems. Continued research and innovation, coupled with supportive policies and large-scale manufacturing, are essential to drive down costs and promote sustainable energy transitions.

Moreover, the potential of Artificial Intelligence (AI) and optimization techniques is becoming increasingly important in enhancing the performance of PV systems [118–120]. AI-driven models, particularly machine learning algorithms, can significantly improve energy production forecasting, allowing PV systems to adapt to changing environmental conditions. These techniques can also optimize system design and maintenance, identifying underperforming panels and enabling predictive maintenance, which helps reduce downtime and prolong system life. Additionally, AI can optimize energy management by controlling the distribution of energy, ensuring the most efficient use of stored energy and grid interactions.

## 6. Conclusion

Solar photovoltaic (PV) technology has evolved significantly, driven by continuous advancements in materials, efficiency, and system integration. This review highlights the sector's transition from early photovoltaic discoveries to modern innovations, including bifacial panels, transparent solar cells, and PV-based hydrogen production. These developments have improved efficiency and cost-effectiveness, accelerating global adoption. However, challenges persist, particularly in market integration, technological limitations, and industry maturation.

The future of solar PV depends on overcoming these barriers through sustained innovation, strategic investments, and supportive policies. Key research areas include enhancing energy conversion efficiency, improving energy storage integration, and reducing material costs. Policy measures, such as incentives for decentralized solar adoption and grid modernization, will be crucial in fostering market expansion. Collaboration among researchers, engineers, and policymakers is essential to bridge existing gaps and accelerate solar PV's role in the global energy transition.

As the sector matures, solar PV can further support decentralized energy systems, increasing energy security and reducing dependence on centralized grids. This will be particularly beneficial for remote and off-grid areas, where PV integration can promote sustainable development and energy resilience. By advancing solar PV technology and strengthening its role in diverse energy systems, the industry can contribute significantly to a cleaner, more sustainable energy future.

## CRediT authorship contribution statement

**Saeed Al-Ali:** Writing – review & editing, Writing – original draft, Methodology, Investigation, Conceptualization. **Abdul Ghani Olabi:** Writing – review & editing, Writing – original draft, Supervision, Project administration, Conceptualization. **Montaser Mahmoud:** Writing – review & editing, Writing – original draft, Supervision, Investigation, Conceptualization.

## Declaration of competing interest

The authors declare that they have no known competing financial interests or personal relationships that could have appeared to influence the work reported in this paper.

## Data availability

Data will be made available on request.

## References

- [1] Tyagi VV, Rahim NAA, Rahim NA, Selvaraj JAL. Progress in solar PV technology: Research and achievement. *Renew Sustain Energy Rev* 2013;20:443–61. <https://doi.org/10.1016/j.rser.2012.09.028>.
- [2] Lopez-Pascual D, Valiente-Blanco I, Morrison AP, Diez-Jimenez E. New solar photovoltaics trends toward sustainable development goals. *SDGs Eur Region* 2023;1205–38. [https://doi.org/10.1007/978-3-031-17461-2\\_106](https://doi.org/10.1007/978-3-031-17461-2_106).
- [3] Becerra VG, Valdivia-Lefort P, Barraza R, García JG. Electrical model analysis for bifacial PV modules using real performance data in laboratory. *Energies* 2024;17(23):5868. <https://doi.org/10.3390/en17235868>.
- [4] Awasthi A, et al. Review on sun tracking technology in solar PV system. *Energy Rep* 2020;6:392–405. <https://doi.org/10.1016/j.energy.2020.02.004>.
- [5] Awuku SA, Bennadji A, Muhammad-Sukki F, Sellami N. Myth or gold? The power of aesthetics in the adoption of building integrated photovoltaics (BIPVs). *Energy Nexus* 2021;4:100021. <https://doi.org/10.1016/j.nexus.2021.100021>.
- [6] Chau JLH, Chen R-T, Hwang G-L, Tsai P-Y, Lin C-C. Transparent solar cell window module. *Sol Energy Mater Sol Cells* 2010;94(3):588–91. <https://doi.org/10.1016/j.solmat.2009.12.003>.
- [7] IEA. "Snapshot 2024." International Energy Agency, Photovoltaic Power Systems Programme. <https://iea-pvps.org/snapshot-reports/snapshot-2024/> (accessed April 2, 2025).
- [8] P. S. Molina. "Global installed PV capacity tops 2 TW." *PV Magazine*. <https://www.pv-magazine.com/2024/11/13/global-installed-pv-capacity-tops-2-tw/> (accessed April 2, 2025).
- [9] Al-Shahri OA, et al. Solar photovoltaic energy optimization methods, challenges and issues: A comprehensive review. *J Clean Prod* 2021;284:125465. <https://doi.org/10.1016/j.jclepro.2020.125465>.
- [10] Katiraei F, Agüero JR. Solar PV integration challenges. *IEEE Power Energy Mag* 2011;9(3):62–71. <https://doi.org/10.1109/MPE.2011.940579>.
- [11] Hussin F, Issabayeva G, Aroua MK. Solar photovoltaic applications: opportunities and challenges. *Rev Chem Eng* 2018;34(4):503–28. <https://doi.org/10.1515/revce-2016-0058>.
- [12] Singh PP, Singh S. Realistic generation cost of solar photovoltaic electricity. *Renew Energy* 2010;35(3):563–9. <https://doi.org/10.1016/j.renene.2009.07.020>.
- [13] Mani M, Pillai R. Impact of dust on solar photovoltaic (PV) performance: Research status, challenges and recommendations. *Renew Sustain Energy Rev* 2010;14(9):3124–31. <https://doi.org/10.1016/j.rser.2010.07.065>.
- [14] Almukhtar H, Tjing Lie T, Al-Shohani W. Dust impact on photovoltaic modules: Global data, predictive models, emphasis on chemical composition. *Energy Convers Manage: X* 2024;24:100764. <https://doi.org/10.1016/j.ecmx.2024.100764>.
- [15] Largot S, et al. Experimental study on the effect of operational and environmental conditions on photovoltaic modules productivity in El-Oued region, Algeria. *Energy Convers Manage: X* 2024;23:100655. <https://doi.org/10.1016/j.ecmx.2024.100655>.
- [16] Chowdhury MS, et al. An overview of solar photovoltaic panels' end-of-life material recycling. *Energy Strat Rev* 2020;27:100431. <https://doi.org/10.1016/j.esr.2019.100431>.
- [17] Salimi AH, Dehghani M, Nazariyouya H. Equitable multi-objective optimization of electric power grids in the face of progressive wildfire. In: *2024 IEEE Power & Energy Society Innovative Smart Grid Technologies Conference (ISGT); 2024*. p. 1–5. <https://doi.org/10.1109/ISGT59692.2024.10454205>.
- [18] Okonkwo PC, et al. Solar PV systems under weather extremes: Case studies, classification, vulnerability assessment, and adaptation pathways. *Energy Rep* 2025;13:929–59. <https://doi.org/10.1016/j.energy.2024.12.067>.
- [19] Bosnjaković M, Stojkov M, Katinčić M, Lacković I. Effects of extreme weather conditions on pv systems. *Sustainability* 2023;15(22):16044. <https://doi.org/10.3390/su152216044>.
- [20] Salimi AH, Nazariyouya H. Equitable operational resilience of power distribution grids in the face of progressive wildfires. In: *2023 North American Power Symposium (NAPS); 2023*. p. 1–6. <https://doi.org/10.1109/NAPS58826.2023.10318605>.
- [21] Ceferino L, Lin N. Hurricane risk of solar generation in the United States. *Nat Hazard Rev* 2023;24(4):04023029. <https://doi.org/10.1061/NHREFO.NHENG-1764>.
- [22] Bayod-Rújula AA. Chapter 8 - Solar photovoltaics (PV). *Solar Hydrogen Production* 2019:237–95. <https://doi.org/10.1016/B978-0-12-814853-2.00008-4>.
- [23] Green MA, Dunlop ED, Hohl-Ebinger J, Yoshita M, Kopidakis N, Hao X. Solar cell efficiency tables (version 56). *Prog Photovolt Res Appl* 2020;28(7):629–38. <https://doi.org/10.1002/ppp.3303>.
- [24] Bisquert J. *The physics of solar cells: perovskites, organics, and photovoltaic fundamentals*. CRC Press; 2017.
- [25] Shah A. *Solar cells: basics*. Solar Cells Modules 2020:33–72. <https://doi.org/10.1007/978-3-030-46487-5>.
- [26] Satpathy R, Pamuru V. Chapter 1 - Manufacturing of polysilicon. *Solar PV Power* 2021:1–29. <https://doi.org/10.1016/B978-0-12-817626-9.00001-0>.
- [27] Benda V. 9 - crystalline silicon solar cell and module technology. In: *A Comprehensive Guide to Solar Energy Systems; 2018*. p. 181–213. <https://doi.org/10.1016/B978-0-12-8111479-7.00009-9>.
- [28] Muniyandi V, Reddy Majji VK, Ravindra M, Adireddy R, Balasubramanian AK. Feature selection-based irradiance forecast for efficient operation of a stand-alone PV system. *Green Energy Intell Transport* 2025:100308. <https://doi.org/10.1016/j.geits.2025.100308>.
- [29] Zaghba L, Khennane Benbitour M, Fezzani A, Mekhilef S, Borni A. Comprehensive performance assessment of two grid-tied photovoltaic systems in a hot arid climate: A three-year theoretical and experimental analysis. *Renew Sustain Energy Rev* 2025;216:115643. <https://doi.org/10.1016/j.rser.2025.115643>.
- [30] Ali W, Farooq H, Rehman AU, Awais Q, Jamil M, Noman A. Design considerations of stand-alone solar photovoltaic systems. In: *2018 International Conference on Computing, Electronic and Electrical Engineering (ICE Cube); 2018*. p. 1–6. <https://doi.org/10.1109/ICECUBE.2018.8610970>.
- [31] Hassan A, Al-Abdell YM, Masek M, Bass O. Optimal sizing and energy scheduling of grid-supplemented solar PV systems with battery storage: Sensitivity of reliability and financial constraints. *Energy* 2022;238:121780. <https://doi.org/10.1016/j.energy.2021.121780>.
- [32] Jahangir MH, Salmanpour F, Sadeghitabar E. Feasibility assessment of using Wavestor energy converter in a grid-connected hybrid renewable energy system (a case study). *Energy Convers Manage: X* 2024;24:100784. <https://doi.org/10.1016/j.ecmx.2024.100784>.
- [33] Naiem-Ur-Rahman M, et al. An asymmetric fuzzy-based self-tuned PSO-Optimized MPPT controller for grid-connected solar photovoltaic system. *Energy Convers Manage* 2025;X:100902. <https://doi.org/10.1016/j.ecmx.2025.100902>.
- [34] Sehar F, Pipattanasomporn M, Rahman S. An energy management model to study energy and peak power savings from PV and storage in demand responsive buildings. *Appl Energy* 2016;173:406–17. <https://doi.org/10.1016/j.apenergy.2016.04.039>.
- [35] Pillai GG, Putrus GA, Georgitsioti T, Pearsall NM. Near-term economic benefits from grid-connected residential PV (photovoltaic) systems. *Energy* 2014;68:832–43. <https://doi.org/10.1016/j.energy.2014.02.085>.
- [36] Zhang L, Yu J, Shi Q, Kong Q. An evaluation of the economic benefits of rooftop distributed photovoltaic projects in the whole county in China. *J Clean Prod* 2023;432:139744. <https://doi.org/10.1016/j.jclepro.2023.139744>.
- [37] Xiao H, Song F, Zheng X, Chen J. Community-based energy revolution: An evaluation of China's photovoltaic poverty alleviation Program's economic and social benefits. *Energy Policy* 2023;177:113555. <https://doi.org/10.1016/j.enpol.2023.113555>.
- [38] Leite NH, Guzman Lascano CP, Valente Morais HG, Pereira da Silva LC. Impact of the net-metering policies on solar photovoltaic investments for residential scale: A case study in Brazil. *Renew Energy* 2024;231:120788. <https://doi.org/10.1016/j.renene.2024.120788>.
- [39] Jia X, Du H, Zou H, He G. Assessing the effectiveness of China's net-metering subsidies for household distributed photovoltaic systems. *J Clean Prod* 2020;262:121161. <https://doi.org/10.1016/j.jclepro.2020.121161>.
- [40] "Clean Energy Australia 2010," 2010. [Online]. Available: [https://library.bsl.org.au/jspui/bitstream/1/2206/1/Clean\\_Energy\\_Australia\\_Report.pdf](https://library.bsl.org.au/jspui/bitstream/1/2206/1/Clean_Energy_Australia_Report.pdf).
- [41] NREL. "Best Research-Cell Efficiency Chart." National Renewable Energy Laboratory. <https://www.nrel.gov/pv/cell-efficiency.html> (accessed March 26, 2025).
- [42] Razykov TM, Ferekides CS, Morel D, Stefanakos E, Ullal HS, Upadhyaya HM. Solar photovoltaic electricity: Current status and future prospects. *Sol Energy* 2011;85(8):1580–608. <https://doi.org/10.1016/j.solener.2010.12.002>.
- [43] Becker C, Sontheimer T, Steffens S, Scherf S, Rech B. Polycrystalline silicon thin films by high-rate electronbeam evaporation for photovoltaic applications – Influence of substrate texture and temperature. *Energy Proc* 2011;10:61–5. <https://doi.org/10.1016/j.egypro.2011.10.153>.
- [44] Saga T. Advances in crystalline silicon solar cell technology for industrial mass production. *NPG Asia Mater* 2010;2(3):96–102. <https://doi.org/10.1038/asiamat.2010.82>.
- [45] Ko J, et al. Review on separation processes of end-of-life silicon photovoltaic modules. *Energies* 2023;16(11):4327. <https://doi.org/10.3390/en16114327>.
- [46] Koch C, Ito M, Schubert M. Low-temperature deposition of amorphous silicon solar cells. *Sol Energy Mater Sol Cells* 2001;68(2):227–36. [https://doi.org/10.1016/S0927-0248\(00\)00249-X](https://doi.org/10.1016/S0927-0248(00)00249-X).
- [47] Kim H, Cha K, Fthenakis VM, Sinha P, Hur T. Life cycle assessment of cadmium telluride photovoltaic (CdTe PV) systems. *Sol Energy* 2014;103:78–88. <https://doi.org/10.1016/j.solener.2014.02.008>.
- [48] Scarpulla MA, et al. CdTe-based thin film photovoltaics: Recent advances, current challenges and future prospects. *Sol Energy Mater Sol Cells* 2023;vol. 255: 112289. <https://doi.org/10.1016/j.solmat.2023.112289>.
- [49] Romeo A, Artegianni E. CdTe-based thin film solar cells: past, present and future. *Energies* 2021;14(6). <https://doi.org/10.3390/en14061684>.
- [50] Bagher AM, Vahid MMA, Mohsen M. Types of solar cells and application. *Am J Opt Photon* 2015;3(5):94–113. <https://doi.org/10.11648/j.ajop.20150305.17>.
- [51] Rahmatian M, Sayyaadi H, Ameri M. Indoor photovoltaics: A numerical model of dye-sensitized solar cells based on indoor illumination for the Internet of Things applications. *Energy Conv Manage: X* 2024;22:100606. <https://doi.org/10.1016/j.ecmx.2024.100606>.
- [52] O'Regan B, Grätzel M. A low-cost, high-efficiency solar cell based on dye-sensitized colloidal TiO<sub>2</sub> films. *Nature* 1991;353(6346):737–40. <https://doi.org/10.1038/353737a0>.
- [53] N. Papež, L. Škvarenina, P. Tofel, and D. Sobola, Thermal stability of gallium arsenide solar cells, vol. 10603, pp. 251–256, 2017, doi: <https://doi.org/10.1117/1.2292673>.
- [54] Chowdhury TA, Zafar MAB, Islam M-S-U, Shahinuzzaman M, Islam MA, Khandaker MU. Stability of perovskite solar cells: issues and prospects. *RSC Adv* 2023;13(3):1787–810. <https://doi.org/10.1039/D2RA05903G>.
- [55] Chang W-C, Lan D-H, Lee K-M, Wang X-F, Liu C-L. Controlled deposition and performance optimization of perovskite solar cells using ultrasonic spray-coating

- of photoactive layers. *ChemSusChem* 2017;10(7):1405–12. <https://doi.org/10.1002/cssc.201601711>.
- [56] Reyna Y, Salado M, Kazim S, Pérez-Tomas A, Ahmad S, Lira-Cantu M. Performance and stability of mixed FAPbI<sub>3</sub>(0.85)MAPbBr<sub>3</sub>(0.15) halide perovskite solar cells under outdoor conditions and the effect of low light irradiation. *Nano Energy* 2016;30:570–9. <https://doi.org/10.1016/j.nanoen.2016.10.053>.
- [57] Wojciechowski K, Forgács D, Rivera T. Industrial opportunities and challenges for perovskite photovoltaic technology. *Sol RRL* 2019;3(9):1900144. <https://doi.org/10.1002/solr.201900144>.
- [58] Yan J, Savenije TJ, Mazzarella L, Isabella O. Progress and challenges on scaling up of perovskite solar cell technology. *Sustain Energy Fuels* 2022;6(2):243–66. <https://doi.org/10.1039/D1SE01045J>.
- [59] Rong Y, et al. Challenges for commercializing perovskite solar cells. *Science* 2018; 361(6408):eaat8235. <https://doi.org/10.1126/science.aat8235>.
- [60] Ahmed MI, Habib A, Javaid SS. Perovskite solar cells: potentials, challenges, and opportunities. *Int J Photoenergy* 2015;2015(1):592308. <https://doi.org/10.1155/2015/592308>.
- [61] Zhou D, Zhou T, Tian Y, Zhu X, Tu Y. Perovskite-based solar cells: materials, methods, and future perspectives. *J Nanomater* 2018;2018(1):8148072. <https://doi.org/10.1155/2018/8148072>.
- [62] Li G, Zhu R, Yang Y. Polymer solar cells. *Nat Photon* 2012;6(3):153–61. <https://doi.org/10.1038/nphoton.2012.11>.
- [63] Chen LX. *Organic Solar Cells: Recent progress and challenges*. ACS Publications; 2019. p. 2537–9.
- [64] Cheng P, Zhan X. Stability of organic solar cells: challenges and strategies. *Chem Soc Rev* 2016;45(9):2544–82. <https://doi.org/10.1039/C5CS00593K>.
- [65] Dash BP, Kumar Beriha S, Naik B, Kumar Sahoo P. Organic materials based solar cells. *Mater. Today: Proc.* 2022;67:1057–63. <https://doi.org/10.1016/j.matpr.2022.07.002>.
- [66] Barranco A, Borrás A, Gonzalez-Eliphe AR, Palmero A. Perspectives on oblique angle deposition of thin films: From fundamentals to devices. *Prog Mater Sci* 2016;76:59–153. <https://doi.org/10.1016/j.pmatsci.2015.06.003>.
- [67] Derouiche H, Djara V. Impact of the energy difference in LUMO and HOMO of the bulk heterojunctions components on the efficiency of organic solar cells. *Sol Energy Mater Sol Cells* 2007;91(13):1163–7. <https://doi.org/10.1016/j.solmat.2007.03.015>.
- [68] Musazade E, et al. Biohybrid solar cells: Fundamentals, progress, and challenges. *J Photochem Photobiol C: Photochem Rev* 2018;35:134–56. <https://doi.org/10.1016/j.jphotochemrev.2018.04.001>.
- [69] Gizzie EA, LeBlanc G, Jennings GK, Cliffl DE. Electrochemical preparation of photosystem I-polyaniline composite films for biohybrid solar energy conversion. *ACS Appl Mater Interf* 2015;7(18):9328–35. <https://doi.org/10.1021/acsami.5b01065>.
- [70] Pandey AK, Tyagi VV, Selvaraj JAL, Rahim NA, Tyagi SK. Recent advances in solar photovoltaic systems for emerging trends and advanced applications. *Renew Sustain Energy Rev* 2016;53:859–84. <https://doi.org/10.1016/j.rser.2015.09.043>.
- [71] S. P. Philipps, A. W. Bett, K. Horowitz, and S. Kurtz, “Current Status of Concentrator Photovoltaic (CPV) Technology,” United States, 2015-12-01 2015. [Online]. Available: <https://www.osti.gov/biblio/1351597>[Online]. Available: <https://www.osti.gov/servlets/purl/1351597>.
- [72] Vogl B, et al. The use of silicon nitride in buried contact solar cells. *Sol Energy Mater Sol Cells* 2001;66(1):17–25. [https://doi.org/10.1016/S0927-0248\(00\)00153-7](https://doi.org/10.1016/S0927-0248(00)00153-7).
- [73] Baumgartner F. 5 - Photovoltaic (PV) balance of system components: Basics, performance. *Performance Photovolt. (PV) Syst.* 2017:135–81. <https://doi.org/10.1016/B978-1-78242-336-2.00005-7>.
- [74] Deambi S, Power SPV. A global perspective. *The Energy and Resources Institute (TERI)*. 2011.
- [75] “The history of solar.” U.S. Department of Energy. [https://www1.eere.energy.gov/solar/pdfs/solar\\_timeline.pdf](https://www1.eere.energy.gov/solar/pdfs/solar_timeline.pdf) (accessed November 19, 2024).
- [76] “Start with the world’s first solar panel.” QSUPPER. <https://qsupersolar.com/how-to-enable-e-bill/> (accessed November 19, 2024).
- [77] Oni AM, Mohsin ASM, Rahman MM, Hossain Bhuiyan MB. A comprehensive evaluation of solar cell technologies, associated loss mechanisms, and efficiency enhancement strategies for photovoltaic cells. *Energy Rep* 2024;11:3345–66. <https://doi.org/10.1016/j.energy.2024.03.007>.
- [78] Smith KD, Gummel HK, Bode JD, Cuttriss DB, Nielsen RJ, Rosenzweig W. The solar cells and their mounting. *Bell Syst Tech J* 1963;42(4):1765–816. <https://doi.org/10.1002/j.1538-7305.1963.tb04050.x>.
- [79] Kamal N, Singh KP. Research review of solar photovoltaic electrical power generation. *Ge-Internat. J. Eng. Res.* 2014;2(8):47–57.
- [80] J. Garofalo, An electricity regulation primer—the history of electricity regulation in the United States, Available at SSRN 3974880, 2021, doi: <https://dx.doi.org/10.2139/ssrn.3974880>.
- [81] Yilmaz S, Dincer F. Impact of inverter capacity on the performance in large-scale photovoltaic power plants – A case study for Gainesville, Florida. *Renew Sustain Energy Rev* 2017;79:15–23. <https://doi.org/10.1016/j.rser.2017.05.054>.
- [82] Green MA. Silicon photovoltaic modules: a brief history of the first 50 years. *Prog Photovolt Res Appl* 2005;13(5):447–55. <https://doi.org/10.1002/PIP.612>.
- [83] Green MA, Emery K. Solar cell efficiency tables. *Prog Photovolt Res Appl* 1993;1(1):25–9. <https://doi.org/10.1002/PIP.4670010104>.
- [84] Oliver M, Jackson T. The market for solar photovoltaics. *Energy Policy* 1999;27(7):371–85. [https://doi.org/10.1016/S0301-4215\(99\)00038-5](https://doi.org/10.1016/S0301-4215(99)00038-5).
- [85] Hoffmann W. PV solar electricity industry: Market growth and perspective. *Sol Energy Mater Sol Cells* 2006;90(18):3285–311. <https://doi.org/10.1016/j.solmat.2005.09.022>.
- [86] Kılıç U, Kekezoğlu B. A review of solar photovoltaic incentives and Policy: Selected countries and Turkey. *Ain Shams Eng J* 2022;13(5):101669. <https://doi.org/10.1016/j.asej.2021.101669>.
- [87] Maycock PD. International photovoltaic markets, developments and trends forecast to 2010. *Renew Energy* 1995;6(5):469–75. [https://doi.org/10.1016/0960-1481\(95\)00062-0](https://doi.org/10.1016/0960-1481(95)00062-0).
- [88] Maycock PD. V-3 - world photovoltaic markets. In: *Practical Handbook of Photovoltaics*; 2003. p. 887–912. [10.1016/B978-185617390-2/50039-8](https://doi.org/10.1016/B978-185617390-2/50039-8).
- [89] L. J. Ehernberger, C. Donohue, and E. H. Teets Jr, “A review of solar-powered aircraft flight activity at the Pacific missile range test facility, Kauai, Hawaii,” 2004.
- [90] Lamnini S, Kádár P. Survey on perspectives of PV technology and their applications. In: 2017 IEEE 15th International Symposium on Applied Machine Intelligence and Informatics (SAMII); 2017. p. 000503–10. doi: <https://doi.org/10.1109/SAMI.2017.7880362>.
- [91] Diouf B, Muley A, Poda R. Issues, challenges, and future perspectives of perovskites for energy conversion applications. *Energies* 2023;16(18). <https://doi.org/10.3390/en16186498>.
- [92] Radwan A, Mahmoud M, Olabi A-G, Rezk A, Maghrabee HM, Abdelkareem MA. Thermal comparison of mono-facial and bi-facial photovoltaic cells considering the effect of TPT layer absorptivity. *Internat. J. Thermofluids* 2023;100306. <https://doi.org/10.1016/j.ijtf.2023.100306>.
- [93] Shahveridian MH, Sayyaadi H, Sohani A. Multi-layer modeling of bifacial photovoltaic panels: evaluating the accuracy of one-, three-, and five-layer models. *Energy Convers Manage*: X 2025;25:100879. <https://doi.org/10.1016/j.ecmx.2025.100879>.
- [94] Zhong J, et al. Development and challenges of bifacial photovoltaic technology and application in buildings: A review. *Renew Sustain Energy Rev* 2023;187: 113706. <https://doi.org/10.1016/j.rser.2023.113706>.
- [95] Kopecek R, Libal J. Bifacial photovoltaics 2021: Status, opportunities and challenges. *Energies* 2021;14(8):2076. <https://doi.org/10.3390/en14082076>.
- [96] Schmid C, Alpert S. A review of roof integrated photovoltaics systems. In: 2022 International Conference on Electrical, Computer and Energy Technologies (ICECET); 2022. p. 1–4. <https://doi.org/10.1109/ICECET55527.2022.9873532>.
- [97] Wöhrle N, et al. Solar cell demand for bifacial and singulated-cell module architectures. *Photovolt Internat* 2017;36:48–62.
- [98] Chow T-T, Li C, Lin Z. Innovative solar windows for cooling-demand climate. *Sol Energy Mater Sol Cells* 2010;94(2):212–20. <https://doi.org/10.1016/j.solmat.2009.09.004>.
- [99] Nguyen TT, Patel M, Kim J. All-inorganic metal oxide transparent solar cells. *Sol Energy Mater Sol Cells* 2020;vol. 217:110708. <https://doi.org/10.1016/j.solmat.2020.110708>.
- [100] Fu Y. Research progress and prospect of translucent organic photovoltaic cells. *Highlights Sci Eng Technol* 2024;106:450–8. <https://doi.org/10.54097/pthvqp46>.
- [101] Xu K, Du M, Hao L, Mi J, Yu Q, Li S. A review of high-temperature selective absorbing coatings for solar thermal applications. *J Materiomics* 2020;6(1): 167–82. <https://doi.org/10.1016/j.jmat.2019.12.012>.
- [102] Roth P, Georgiev A, Boudinov H. Cheap two axis sun following device. *Energy Convers Manage* 2005;46(7):1179–92. <https://doi.org/10.1016/j.enconman.2004.06.015>.
- [103] Dekkiche M, Tahri T, Denai M. Techno-economic comparative study of grid-connected PV/reformer/FC hybrid systems with distinct solar tracking systems. *Energy Convers Manage*: X 2023;18:100360. <https://doi.org/10.1016/j.ecmx.2023.100360>.
- [104] Quesada G, Guillon L, Rouse DR, Mehrash M, Dutil Y, Paradis P-L. Tracking strategy for photovoltaic solar systems in high latitudes. *Energy Convers Manage* 2015;103:147–56. <https://doi.org/10.1016/j.enconman.2015.06.041>.
- [105] Dehghani M, Taghipour M, Gharehpetian GB, Abedi M. Optimized fuzzy controller for MPPT of grid-connected PV systems in rapidly changing atmospheric conditions. *J Mod Power Syst Clean Energy* 2021;9(2):376–83. <https://doi.org/10.35833/MPCE.2019.000086>.
- [106] Abdelkareem MA, et al. Optimized solar photovoltaic-powered green hydrogen: Current status, recent advancements, and barriers. *Solar Energy* 2023;112072. <https://doi.org/10.1016/j.solener.2023.08.321>.
- [107] Li X, Raorane CJ, Xia C, Wu Y, Tran TKN, Khademi T. Latest approaches on green hydrogen as a potential source of renewable energy towards sustainable energy: Spotlighting of recent innovations, challenges, and future insights. *Fuel* 2023;334: 126684. <https://doi.org/10.1016/j.fuel.2022.126684>.
- [108] Hosseini SE, Wahid MA. Hydrogen production from renewable and sustainable energy resources: Promising green energy carrier for clean development. *Renew Sustain Energy Rev* 2016;57:850–66. <https://doi.org/10.1016/j.rser.2015.12.112>.
- [109] Hassan Q, Algburi S, Sameen AZ, Salman HM, Jaszczur M. Green hydrogen: A pathway to a sustainable energy future. *Int J Hydrogen Energy* 2024;50:310–33. <https://doi.org/10.1016/j.ijhydene.2023.08.321>.
- [110] Allouhi A, Rehman S, Buker MS, Said Z. Up-to-date literature review on Solar PV systems: Technology progress, market status and R&D. *J Clean Prod* 2022;362: 132339. <https://doi.org/10.1016/j.jclepro.2022.132339>.
- [111] Gupta V, Sharma M, Pachauri RK, Dinesh Babu KN. Comprehensive review on effect of dust on solar photovoltaic system and mitigation techniques. *Sol Energy* 2019;191:596–622. <https://doi.org/10.1016/j.solener.2019.08.079>.

- [112] Darwish ZA, Kazem HA, Sopian K, Al-Goul MA, Alawadhi H. Effect of dust pollutant type on photovoltaic performance. *Renew Sustain Energy Rev* 2015;41: 735–44. <https://doi.org/10.1016/j.rser.2014.08.068>.
- [113] Hasanuzzaman M, Malek ABMA, Islam MM, Pandey AK, Rahim NA. Global advancement of cooling technologies for PV systems: A review. *Sol Energy* 2016; 137:25–45. <https://doi.org/10.1016/j.solener.2016.07.010>.
- [114] Sheik MS, Kakati P, Dandotiya D, U. R. M R. C. S. A comprehensive review on various cooling techniques to decrease an operating temperature of solar photovoltaic panels. *Energy Nexus* 2022;8:100161. <https://doi.org/10.1016/j.nexus.2022.100161>.
- [115] Cherp A, Vinichenko V, Jewell J, Suzuki M, Antal M. Comparing electricity transitions: A historical analysis of nuclear, wind and solar power in Germany and Japan. *Energy Policy* 2017;101:612–28. <https://doi.org/10.1016/j.enpol.2016.10.044>.
- [116] Boukourt NE, Triolo C, Santangelo S, Patanè S. All-Perovskite tandem solar cells: from certified 25% and beyond. *Energies* 2023;16(8). <https://doi.org/10.3390/en16083519>.
- [117] IRENA. *Global Energy Transformation: A roadmap to 2050*. International Renewable Energy Agency, Abu Dhabi. 2018.
- [118] Mateo Romero HF, et al. Applications of artificial intelligence to photovoltaic systems: a review. *Appl. Sci.* 2022;12(19). <https://doi.org/10.3390/app121910056>.
- [119] Mohammad A, Mahjabeen F. Revolutionizing solar energy: The impact of artificial intelligence on photovoltaic systems. *Internat J Multidiscipl Sci Arts* 2023;2(3):591856. <https://doi.org/10.47709/ijmdsa.v2i1.2599>.
- [120] Kurukuru VS, Haque A, Khan MA, Sahoo S, Malik A, Blaabjerg F. A review on artificial intelligence applications for grid-connected solar photovoltaic systems. *Energies* 2021;14(15). <https://doi.org/10.3390/en14154690>.